

# brother

## LK3-B430

高速本縫筒型門止ミシン

HIGH SPEED BAR TACKING MACHINE

VERRIEGELUNGSSCHNELLNÄHER

MACHINE À COUDRE À POINTS D'ARRÊT À GRANDE VITESSE DU TYPE BRAS LIBRE

MÁQUINA PRESILLADORA DE DOBLE PESPUNTE DE ALTA VELOCIDAD CON BARRA DE BRAZO LIBRE

パーツブック

PARTS BOOK

TEILEKATALOG

LIVRE DES PIÈCES

LIBRO DE REFERENCIA DE PIEZAS

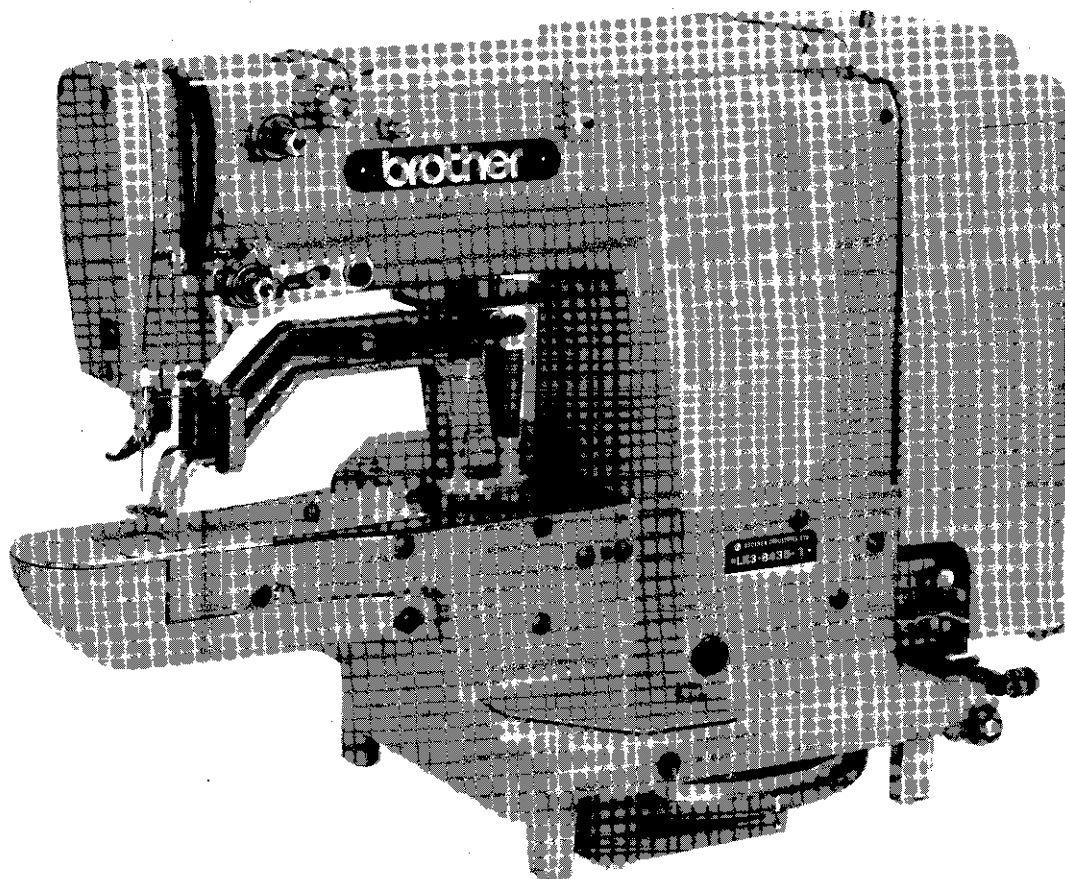

P430501

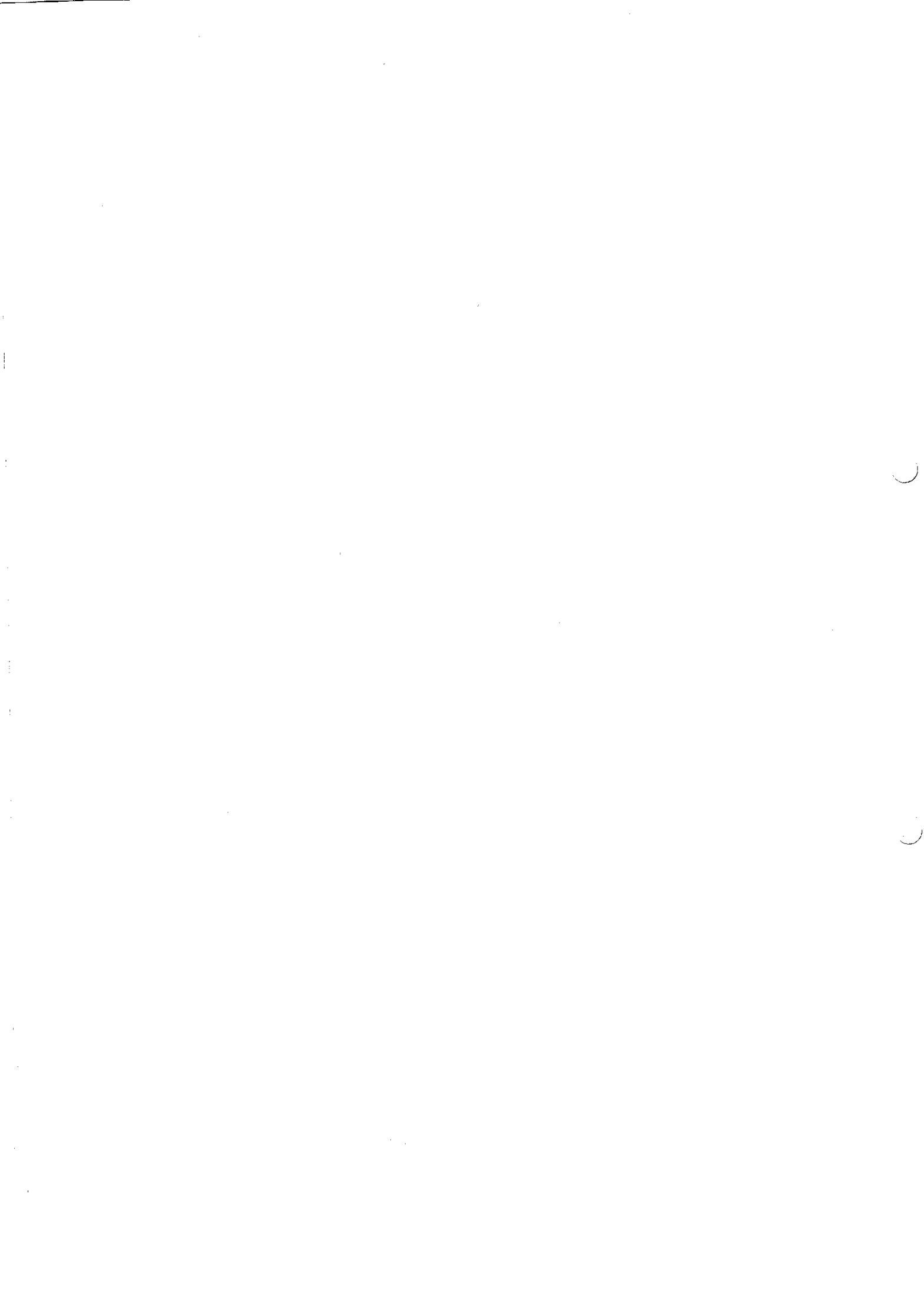

## パーツブックご利用に際して

1. この本は、この本の表紙（正誤表の挿入されている場合は正誤表）に記載されているものと同じプレートが取り付けられているミシンのためのものです。
2. 部品コード欄が\*となっている場合は、ゲージ部品一覧表（41～44ページ）でお調べ下さい。
3. この本は1991年1月のデータに基づいて作成されたものです。
4. 部品は、予告なしに設計変更される場合があります。

## 目 次

A. 主体関係	2
B. クラッチ関係	6
C. 上軸・針棒関係	10
D. 動車・遊車関係	12
E. 補給部品	12
F. 送り関係	14
G. 押エ上ゲ関係	18
H. カム伝導関係	20
J. パワー押エ関係	22
K. 下軸関係	24
L. 給油潤滑関係	26
M. 糸通シ関係	30
N. 糸巻き関係	32
P. 糸切り関係	34
Q. 糸払い関係	36
R. 糸締メ関係	36
S. 付属装置セット	38
T. 特別注文部品	38
Z. 付属品関係	40
仕様別部品一覧表	41～44
オプションパーツ	45
索引	46～53

## Notes for using this parts book

1. This book is applicable to sewing machines which have the same plate number as shown on the cover of this book (or correction sheet).
2. If the symbol \* is found in the "Parts No." column, refer to the different parts list on page 41~44.
3. This book was prepared based on information available in January 1991.
4. Parts are subject to changes in design without prior notice.

## CONTENTS

A. Machine body .....	2
B. Clutch mechanism .....	6
C. Upper shaft and needle bar mechanism .....	10
D. Drive pulley and idler pulley mechanism .....	12
E. Supply parts .....	12
F. Feed mechanism .....	14
G. Work clamp lifter mechanism .....	18
H. Vertical shaft mechanism .....	20
J. Power lift mechanism .....	22
K. Lower shaft mechanism .....	24
L. Lubrication .....	26
M. Threading mechanism .....	30
N. Bobbin winder mechanism .....	32
P. Thread trimmer mechanism .....	34
Q. Thread wiper mechanism .....	36
R. Thread nipper mechanism .....	36
S. Attachment set .....	38
T. Option Parts .....	38
Z. Accessories .....	40
DIFFERENT PARTS LIST .....	41 ~ 44
OPTION PARTS .....	45
INDEX .....	46 ~ 53

## Hinweise zur Verwendung dieser Teileliste

1. Dieses Buch bezieht sich auf die Nähmaschinen mit derselben Kennungsnummer wie auf diesem Buchumschlag (oder auf dem Korrekturblatt).
2. Dieses Zeichen \* in der Spalte "Parts No. (Teilnummer)" verweist auf Gesonderte Stückliste auf Seite 41-44.
3. Dieses Buch basiert auf den Informationen vom Januar 1991.
4. Modelländerungen sind vorbehalten.

## INHALTSVERZEICHNIS

A. Maschinengehäuse .....	2
B. Kupplungsvorrichtung .....	6
C. Obere Welle und Nadelstangenvorrichtung .....	10
D. Antriebsriemenscheibe und Riemenscheibe .....	12
E. Lieferteile .....	12
F. Transportvorrichtung .....	14
G. Stoffhalterhebervorrichtung .....	18
H. Vertikale Welle .....	20
J. Heberbetätigungsvorrichtung .....	22
K. Untere Welle .....	24
L. Schmierung .....	26
M. Fadenführungsvorrichtung .....	30
N. Spuler .....	32
P. Fadenabschneidevorrichtung .....	34
Q. Fadenwischvorrichtung .....	36
R. Fadenspannvorrichtung .....	36
S. Anbausatz .....	38
T. Sonderzubehör .....	38
Z. Zubehör .....	40
ZUBEHÖRLISTE .....	41 ~ 44
SONDERZUBEHÖR .....	45
VERZEICHNIS .....	46 ~ 53

## Notes sur l'utilisation de ce manuel de pièces détachées

1. Ce manuel est destiné aux machines à coudre ayant le même numéro de plaque montré sur la couverture de ce manuel (ou sur la feuille de corrections).
2. Si le symbole \* se trouve dans la colonne "Parts No. (N° de pièce)", veuillez vous référer à la liste de pièces annexe page 41~44.
3. Ce manuel a été fait d'après les renseignements valables au mois de Janvier 1991.
4. Les pièces peuvent être sujettes à des modification sans préavis.

### TABLE DES MATIERES

A. Corps de la machine .....	2
B. Mécanisme de l'embrayage .....	6
C. Mécanisme de arbre supérieur et barre à aiguille .....	10
D. Mécanisme de poulie d'entraînement et poulie folle .....	12
E. Pièces fournies .....	12
F. Mécanisme de l'entraînement .....	14
G. Mécanisme de leueur du pinceur .....	18
H. Mécanisme d'arbre vertical .....	20
J. Mécanisme de leueur .....	22
K. Mécanisme de l'arbre inférieur .....	24
L. Lubrification .....	26
M. Mécanisme de l'enfilage .....	30
N. Mécanisme de bobineur .....	32
P. Mécanisme de coupe-fil .....	34
Q. Mécanisme de tire-fil .....	36
R. Mécanisme de pince-fil .....	36
S. Jeu d'accessoires .....	38
T. Pièces en option .....	38
Z. Accessoires .....	40
LISTE DES PIECES ACCESSOIRES .....	41 ~ 44
PIECES EN OPTION .....	45
INDEX .....	46 ~ 53

## Notas para usar este Manual de Piezas

1. Este libro sirve para todas las máquinas de coser que llevan la misma placa de identificación que la que se puede ver en la tapa de este libro (o en la hoja de erratas).
2. De haber un símbolo \* junto al "Parts No. (Número de pieza)", habrá que mirar la lista de piezas separada de la página 41~44.
3. Este libro ha sido compilado basándose en los datos de que se disponía en enero de 1991.
4. Las piezas quedan sujetas a cambios de diseño sin aviso previo.

## INDICE

A. Cuerpo de la máquina .....	2
B. Mecanismo de embrague .....	6
C. Mecanismo del eje superior y barra de aguja .....	10
D. Mecanismo de polea impulsora y polea tensora .....	12
E. Piezas de suministro .....	12
F. Mecanismo de la alimentación .....	14
G. Mecanismo del levantador de ménsula de trabajo .....	18
H. Mecanismo de eje vertical .....	20
J. Mecanismo de carrera de potencia .....	22
K. Mecanismo del eje inferior .....	24
L. Lubricación .....	26
M. Mecanismo del enhebrado .....	30
N. Mecanismo del devanador de la canilla .....	32
P. Mecanismo de la cortadura de hilos .....	34
Q. Mecanismo del limpiador de hilo .....	36
R. Mecanismo de la mordaza para hilo .....	36
S. Juego de fijación .....	38
T. Piezas opcionales .....	38
Z. Accesorios .....	40
LISTA DE PIEZAS ACCESORIAS .....	41 ~ 44
PIEZAS OPCIONALES .....	45
INDICE .....	46 ~ 53

A. 主体関係 / Machine body / Maschinengehäuse / Corps de la machine / Cuerpo de la máquina

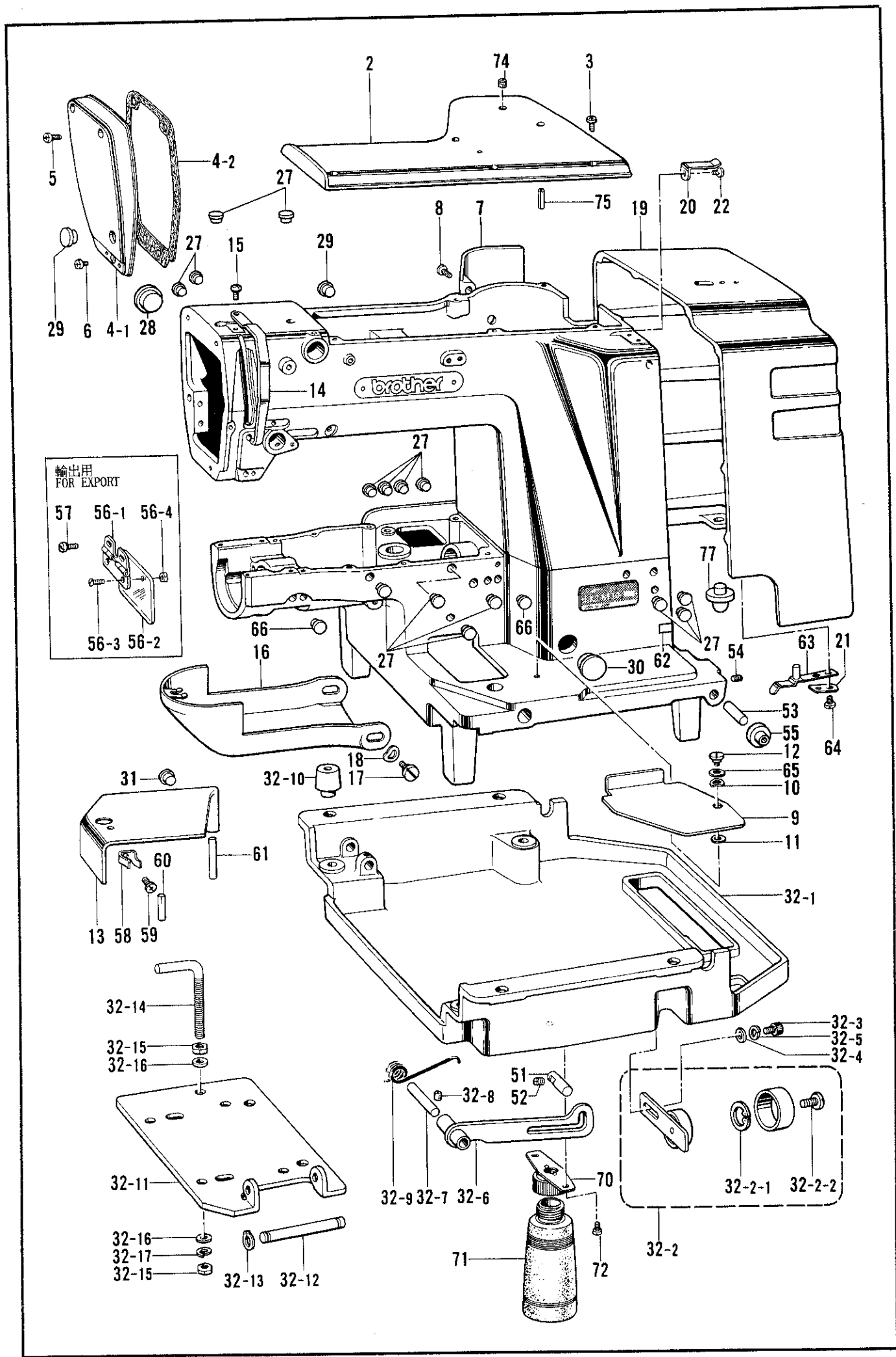



A. 主体関係 / Machine body / Maschinengehäuse / Corps de la machine / Cuerpo de la máquina

REF.NO.	CODE	Q'TY	ヒンメイ	NAME OF PARTS	RMKS
2	152830109	1	ウフフタ	TOP COVER	
3	062761412	6	ナヘ"コ595-28X14	SCREW 595X14	
4	152831009	1	メンイタクミ	FACE PLATE ASSEMBLE	
4-1	152832109	1	メンイタ	FACE PLATE	
4-2	152833001	1	メンイタパ"ツキン	PACKING	
5	062711412	2	ナヘ"コ4.76-32X14	SCREW 476X14	
6	062710712	1	ナヘ"コ476-32X7	SCREW 476X7	
7	152834009	1	ソクメンカハ"	FRAME SIDE COVER	
8	062711412	4	ナヘ"コ4.76-32X14	SCREW 476X14	
9	152835009	1	ヘ"ツト"カハ"-R	BED COVER(R)	
10	100315002	1	ナミハ"ネ	WAVE SPRING	
11	025770232	1	ヒラサ"ガ"ネチユウ6.35	PLAIN WASHER 6.35	
12	145480001	1	ダ"ンネジ"6.35	STUD SCREW 6.35	
13	152836009	1	ヘ"ツト"カハ"-Lクミ	BED COVER (L) ASSEMBLY	
14	152841009	1	デンヒ"ンカハ"	THREAD TAKE-UP COVER	
15	062670812	1	ナヘ"コ357-40X8	SCREW 357X8	
16	152842009	1	オオカマカハ"-クミ	LARGE SHUTTLE HOOK COVER ASSEMBLY (B)	
17	115493002	2	ダ"ンネジ"5.95	STUD SCREW 5.95	
18	109239002	2	ナミハ"ネサ"ガ"ネ	SPRING WASHER	
19	152846009	1	ヘ"ルトカハ"	BELT COVER	
20	152989001	1	ヘ"ルトカハ"-ハ"ネウケ	SPRING PLATE	
21	152986001	1	ヘ"ルトカハ"-ハ"ネササエ	SPRING SUPPORT	
22	062680812	1	ナヘ"コ437-40X8	SCREW 437X8	
27	117936009	15	メクラセン	OIL CAP	
28	140392009	1	オイルフタ	OIL CAP	
29	117934009	2	メクラセン	OIL CAP	
30	108520009	1	メクラセン	OIL CAP	
31	104450109	1	メクラセン	OIL CAP	
32	159808109	1	オイルパンクミ	OIL PAN ASSEMBLY	
32-1	154738109	1	オイルパン	OIL PAN	
32-2	152852101	1	デンジョンプ"ーリクミ	TENSION PULLEY ASSEMBLY	
32-2-1	048320242	1	トメワアナヨウC32	STOP RING C32	
32-2-2	141860001	1	シメネジ"6.35	SCREW 6.35	
32-3	018081222	1	アナホ"ルト8X12	BOLT 8X12	
32-4	025080232	1	ヒラサ"ガ"ネチユウ8	PLAIN WASHER 8	
32-5	028080242	1	ハ"ネサ"ガ"ネ2-8	SPRING WASHER 2-8	
32-6	152857001	1	トウフ"ササエレハ"	HEAD SUPPORT LEVER	
32-7	152858001	1	トウフ"ササエレハ"-シ"ク	HEAD SUPPORT LEVER SHAFT	
32-8	013719412	1	トメネジ"4.76クホ"ミ	SET SCREW 4.76	
32-9	152859001	1	トウフ"ササエレハ"-ハ"ネ	SPRING	
32-10	152860009	4	ヘ"ツト"クツシヨ	BED CUSHION	
32-11	152861101	1	モ"ター"ダ"イ	MOTOR BASE PLATE	
32-12	152862001	1	モ"ター"ダ"イ"シ"ク	MOTOR BASE PLATE SHAFT	
32-13	048100142	2	トメフシ"クヨウC10	STOP RING C10	
32-14	152865101	1	L"カ"タホ"ルトM10	(L) BOLT M10	
32-15	021100202	2	ナツト2シユ10	NUT 10	
32-16	025100132	2	ヒラサ"ガ"ネシヨウ10	PLAIN WASHER 10	
32-17	028100242	1	ハ"ネサ"ガ"ネ2-10	SPRING WASHER 2-10	
51	152866001	1	トウフ"ササエヒ"ン	PIN	
52	013760612	1	トメネジ"5.95クホ"ミ	SET SCREW 5.95	
53	152867000	2	ヘ"ツト"ヒンシ"シ"ク	HINGE SHAFT	
54	151604002	2	トメネジ"5.95	SET SCREW 5.95	
55	152868009	2	ヘ"ツト"ヒンシ"クツシヨ	HINGE CUSHION	
56	153100000	1	-----	EYE GUARD ASSEMBLY	
56-1	153102001	1	-----	EYE GUARD HINGE ASSEMBLY	
56-2	153098000	1	-----	EYE GUARD	
56-3	102538007	2	-----	SCREW 3.57	
56-4	106129001	2	-----	NUT 3.57	
57	062670512	2	-----	SCREW 357X5	
58	114985001	1	ヘ"ツトカハ"-トメハ"ネ	SPRING	
59	062680612	1	ナヘ"コ4.37-40X6	SCREW 437X6	
60	152838001	1	ミゾ"ツキヒ"ン	DOWEL PIN	

A. 主体関係/Machine body/Maschinengehäuse/Corps de la machine/Cuerpo de la máquina

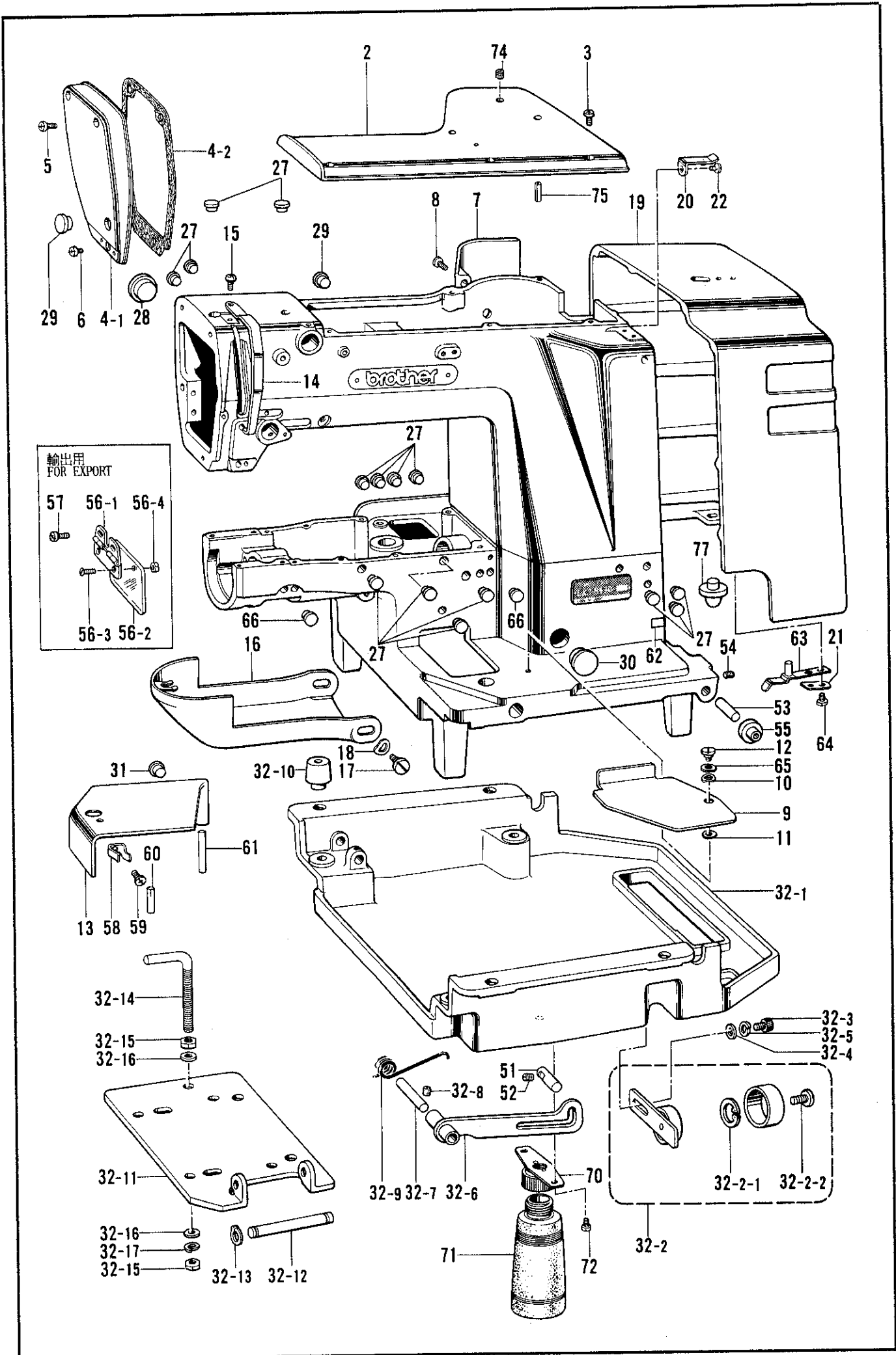

## A. 主体関係 / Machine body / Maschinengehäuse / Corps de la machine / Cuerpo de la máquina

REF.NO.	CODE	Q'TY	ヒンメイ	NAME OF PARTS	RMKS
61	152839001	1	ベッドカバーシャフト	BED COVER SHAFT	
62	*	1	シヨウラベル	LABEL	
63	152848001	1	ヘルトカバーハネ	SPRING	
64	062680812	2	ナヘコ437-40X8	SCREW 437X8	
65	025080132	1	ヒラサカネシヨウ8	WASHER 8	
66	104450109	2	メクラセン	OIL CAP	
70	154465001	1	ハイユキヤツプササエクミ	DUST OILER SUPPORT ASSEMBLY	
71	114486002	1	ホリオイラータイ	OILER	
72	062710612	2	ナヘコ476-32X6	SCREW 476X6	
74	154785000	2	フェルト	FELT	
75	047501242	2	スプリングピンAW5	SPRING PIN AW5	
77	152847009	2	ヘルトカバーゴムサ	PACKING	

B. クラッチ関係 / Clutch mechanism / Kupplungsvorrichtung /  
 Mécanisme de l'embrayage / Mecanismo de embrague

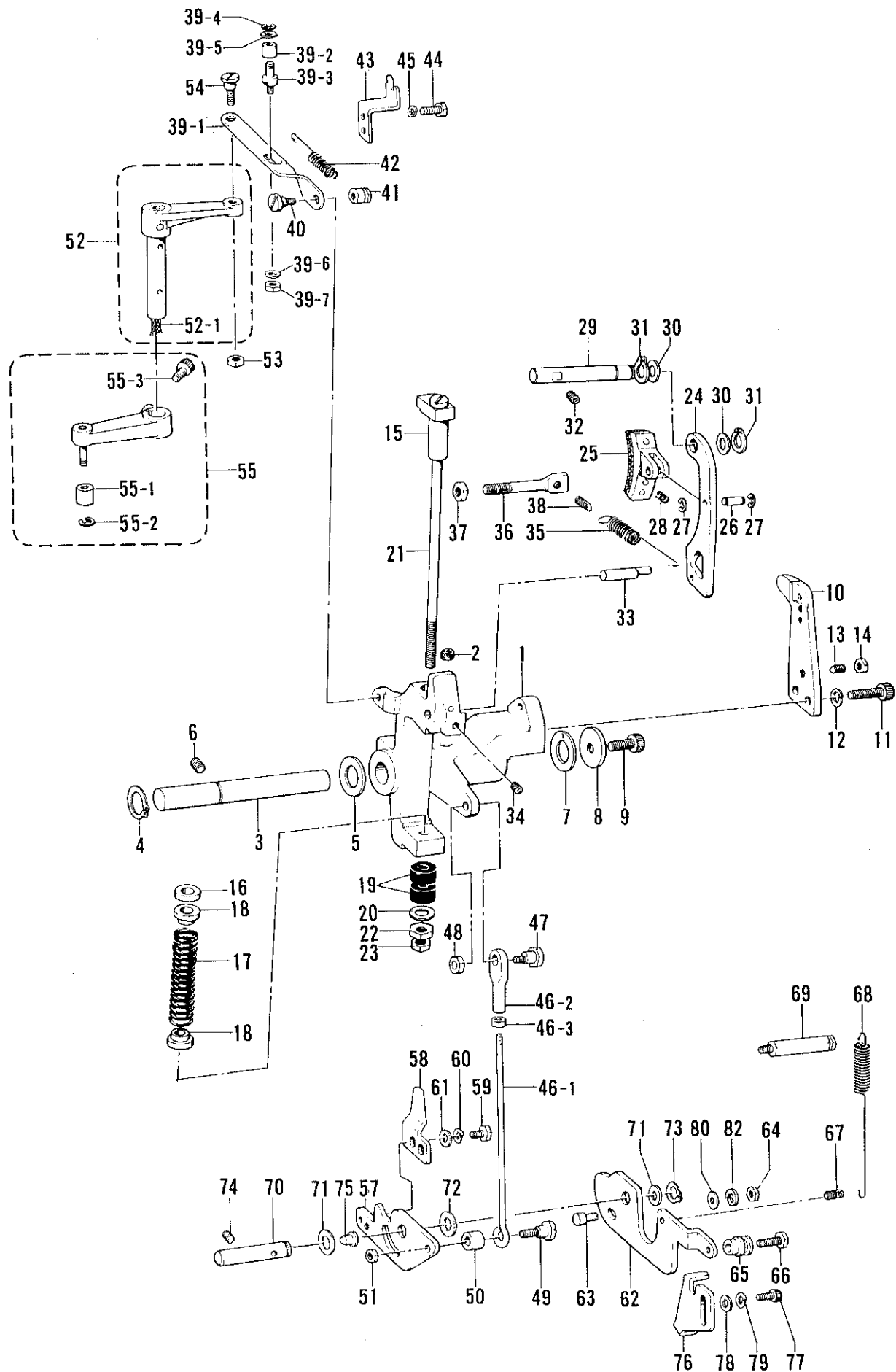

B. クラッチ関係/Clutch mechanism/Kupplungsvorrichtung/  
Mécanisme de l'embrayage/Mecanismo de embrague

REF.NO.	CODE	Q'TY	ヒンメイ	NAME OF PARTS	RMKS
1	151886001	1	クラッチレバー	CLUTCH LEVER	
2	151927001	1	クラッチフェルト	CLUTCH FELT	
3	151887001	1	クラッチレバーシャフト	CLUTCH LEVER SHAFT	
4	048180142	1	トメワC18	STOP RING C18	
5	152756001	1	スラストサカネ18	THRUST WASHER 18	
6	014821022	1	アナトメネジ7.94クホミ	SET SCREW 7.94	
7	151929000	1	スラストサカネ18	THRUST WASHER 18	
8	152728001	1	スラストサカネ8	THRUST WASHER 8	
9	151163001	1	アナホルト8X15	BOLT 8X15	
10	151888101	1	ボールオサエイタ	BALL PRESSER PLATE	
11	018082522	2	アナホルト8X25	BOLT 8X25	
12	028080242	2	ハネサカネ2-8	SPRING WASHER 2-8	
13	115012002	1	トメネジ6.35	SET SCREW 6.35	
14	150554002	1	ナット6.35	NUT 6.35	
15	151889001	1	ストツパタイ	CLUTCH STOPPER	
16	151890000	1	ストツパゴム	STOPPER RUBBER	
17	151891001	1	クラッチハネ	SPRING	
18	151892001	2	ハネウケ	SPRING HOOK	
19	115018001	2	カンシヨウゴム	CUSHION RUBBER	
20	025800332	1	ヒラサカネタテ7.14	PLAIN WASHER 7.14	
21	151893001	1	ストツパシャフト	STOPPER SHAFT	
22	021800102	1	ナット1.14	NUT 1.14	
23	104689002	1	ナット7.14	NUT 7.14	
24	151894101	1	ブレーキレバー	BRAKE LEVER	
25	151895000	1	ブレーキクミ	BRAKE ASSEMBLY	
26	151898001	1	ブレーキシャフト	BRAKE SHAFT	
27	048040342	2	トメワE4	STOP RING E4	
28	151899001	1	ブレーキシユハネ	SPRING	
29	151900001	1	ブレーキレバーシャフト	BRAKE LEVER SHAFT	
30	142628001	2	スイハイオクリクランクリング	FEED ROCK CRANK RING	
31	048110142	2	トメワシクヨウC11	STOP RING C11	
32	013761410	1	トメネジ5.95クホミ	SET SCREW 5.95	
33	151901001	1	ブレーキサトピン	PIN	
34	014760622	1	アナトメネジ5.95	SET SCREW 5.95	
35	151902001	1	ブレーキハネ	SPRING	
36	151903001	1	ブレーキハネカケネジ	SCREW	
37	106147002	1	ナット7.94	NUT 7.94	
38	110251001	1	ヌノオサエウデハネカケ	SPRING HOOK	
39	151904101	1	クラッチレバーレンカンクミ	CLUTCH LEVER ROD ASSEMBLY	
39-1	151905101	1	クラッチレバーレンカン	CLUTCH LEVER ROD	
39-2	107744001	1	コロ	ROLLER	
39-3	151906101	1	レンカンコロシャフト	ROLLER SHAFT	
39-4	048030342	1	トメワE3	STOP RING E3	
39-5	113431002	1	サカネ	WASHER	
39-6	025680132	1	ヒラサカネシヨウ4.37	PLAIN WASHER 4.37	
39-7	021680202	1	ナット2.37	NUT 2.37	
40	151907001	1	タネネジ5.95	STUD SCREW 5.95	
41	151908001	1	ナット5.95	NUT 5.95	
42	155501001	1	クラッチレバーハネ	SPRING	
43	151910001	1	クラッチレバーハネカケ	SPRING HOOK	
44	117363001	2	ホルト4.76	BOLT 4.76	
45	028050242	2	ハネサカネ2-5	SPRING WASHER 2-5	
46	152808101	1	チヨウセツロツトクミ	ADJUST ROD ASSEMBLY	
46-1	154332001	1	オサエアケチヨウセツロツト	PRESSER BAR LIFTER ADJUST ROD	
46-2	154333001	1	オサエアケチヨウセツツキテ	PRESSER BAR LIFTER ADJUST JOINT	
46-3	150556001	1	ナット6.35	NUT 6.35	
47	151912001	1	ハンシンドネジ6.35	STUD SCREW 6.35	
48	150556001	1	ナット6.35	NUT 6.35	
49	151913001	1	タネネジ6.35	STUD SCREW 6.35	
50	151914001	1	カラー13	COLLAR 13	
51	150556001	1	ナット6.35	NUT 6.35	
52	151915101	1	クラッチサトレバークミ	CLUTCH ACTUATING LEVER ASSEMBLY	

B. クラッチ関係 / Clutch mechanism / Kupplungsvorrichtung /  
 Mécanisme de l'embrayage / Mecanismo de embrague

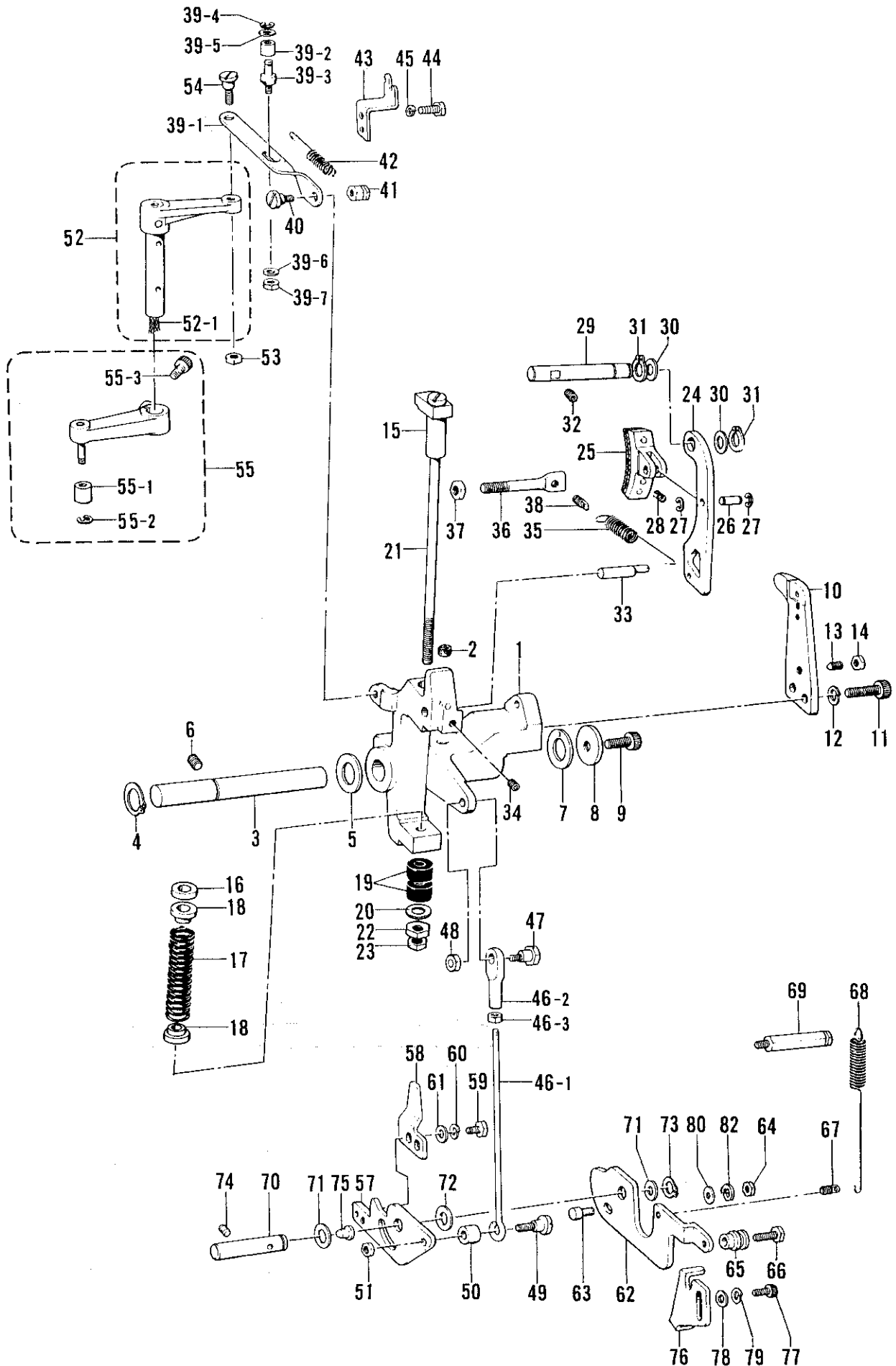

B. クラッチ関係/ Clutch mechanism/Kupplungsvorrichtung/  
Mécanisme de l'embrayage/Mecanismo de embrague

REF.NO.	CODE	Q'TY	ヒンメイ	NAME OF PARTS	RMKS
52-1	152980001	1	クミヒモ6X6 (L=150)	WICK 6X6 (L=150)	
53	150553001	1	ナツト5.95	NUT 5.95	
54	151907001	1	ダンネジ"5.95	STUD SCREW 5.95	
55	151939101	1	クラッチカムレバークミ	CLUTCH CAM LEVER ASSEMBLY	
55-1	152914001	1	コロ	ROLLER	
55-2	048040342	1	トメワE4	STOP RING E4	
55-3	018062022	1	アナボルト6X20	BOLT 6X20	
57	151919101	1	キト"ーレバ"ー	STARTING LEVER	
58	151920001	1	キト"ーセイフレバ"ー	STARTING SAFETY LEVER	
59	017711412	2	ボルト4.76X14	BOLT 4.76X14	
60	028050242	2	ハ"ネサ"ガ"ネ2-5	SPRING WASHER 2-5	
61	113431002	2	サ"カ"ネ	WASHER	
62	155499001	1	Pサト"ーレバ"ー	STARTING LEVER PLATE	
63	154155101	1	ストツハ"ネジ"	STOPPER SCREW	
64	150553001	1	ナツト5.95	NUT 5.95	
65	151922001	1	クサリカケカラー	CHAIN HOOK COLLAR	
66	017762202	1	ボルト5.95X22	BOLT 5.95X22	
67	110251001	1	ヌノオサエウデ"ハ"ネカケ	SPRING HOOK	
68	151923001	1	サト"ーレバ"ー"ハ"ネ	SPRING	
69	151924001	1	サト"ーレバ"ー"ハ"ネカケ	SPRING HOOK	
70	151925001	1	キト"ーレバ"ー"シ"ク	STARTING LEVER SHAFT	
71	142628001	2	スイハイオクリクランクリング"	FEED ROCK CRANK RING	
72	110505001	1	サ"カ"ネ	WASHER	
73	048110142	1	トメワシ"クヨウC11	STOP RING C11	
74	014760622	1	アナトメネジ"5.95	SET SCREW 5.95	
75	111865009	1	オイルメクラセン	OIL CAP	
76	155500001	1	キト"ーストツハ"	STARTING LEVER STOPPER	
77	018061622	2	アナボルト6X16	BOLT 6X16	
78	025060132	2	ヒラサ"ガ"ネシヨウ6	PLAIN WASHER 6	
79	028060242	2	ハ"ネサ"ガ"ネ2-6	SPRING WASHER 2-6	
80	025060232	1	ヒラサ"ガ"ネチユウ6	PLAIN WASHER 6	
82	028060242	1	ハ"ネサ"ガ"ネ2-6	SPRING WASHER 2-6	

C. 上軸・針棒関係 / Upper shaft and needle bar mechanism / Obere Welle und Nadelstangenvorrichtung /  
 Mécanisme de arbre supérieur et barre à aiguille / Mecanismo del eje superior y barra de aguja

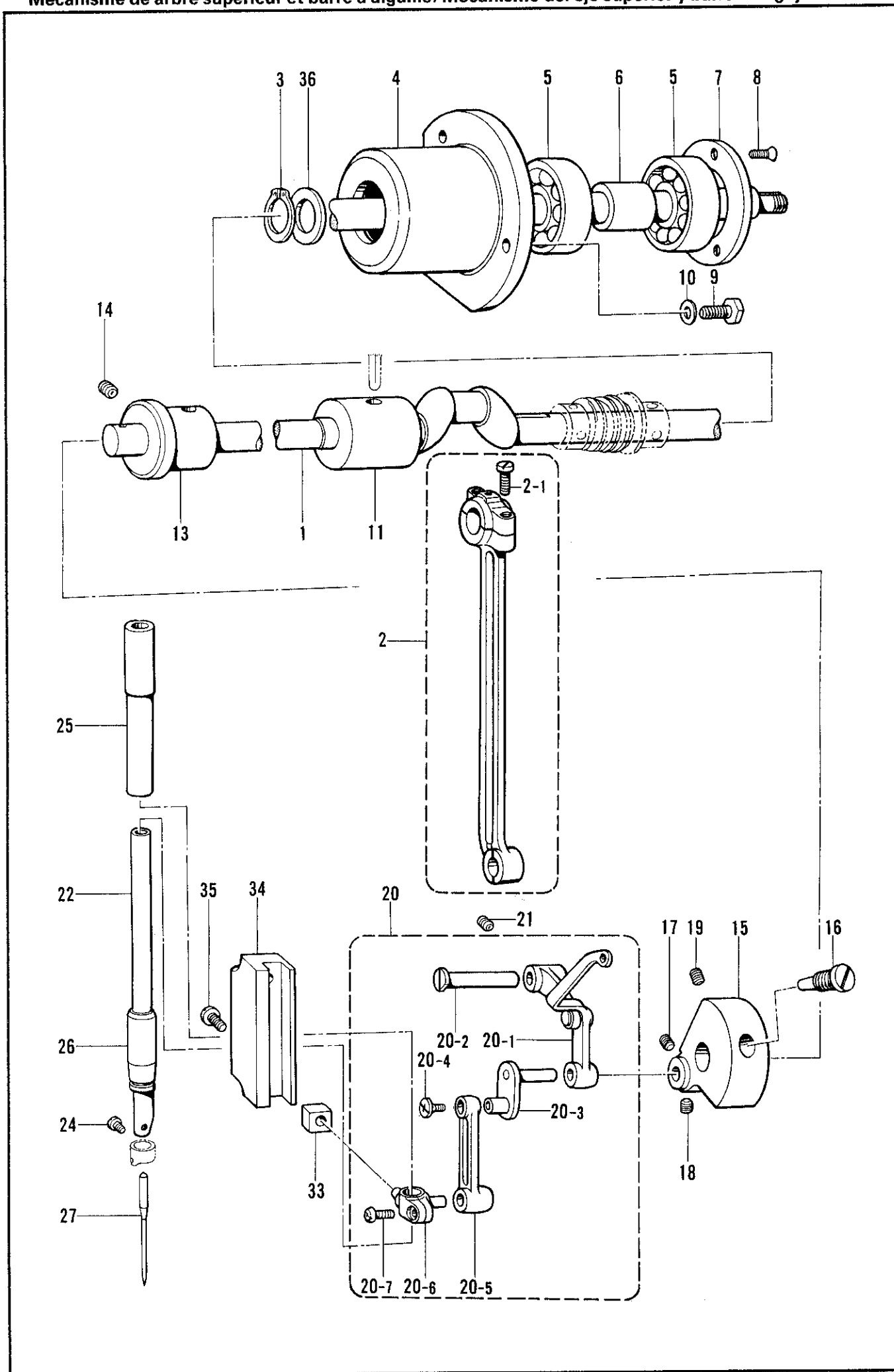



C. 上軸・針棒関係/Upper shaft and needle bar mechanism/Obere Welle und Nadelstangenvorrichtung/  
 Mécanisme de arbre supérieur et barre à aiguille/Mecanismo del eje superior y barra de aguja

REF.NO.	CODE	Q'TY	ヒンメイ	NAME OF PARTS	RMKS
1	151995001	1	ウフジ"ク	UPPER SHAFT	
2	153040001	1	クランクロッド"クミ	CRANK ROD ASSEMBLY	
2-1	144712002	2	シメネジ"4.76	SCREW 4.76	
3	048150142	1	トメウジ"クヨウC15	STOP RING C15	
4	151997000	1	タマシ"クウケケース	BALL BEARING CASE	
5	072630260	2	ハ"アリング"6302VV	BEARING 6302VV	
6	151998000	1	ハ"アリング"カンサ"	BEARING COLLAR	
7	151999001	1	タマシ"クウケフタ	BALL BEARING CAP	
8	102843004	3	サラネジ"3.57	SCREW 3.57	
9	017761412	3	ボ"ルト5.95X14	BOLT 5.95X14	
10	025060232	3	ヒラサ"ガ"ネチユウ6	PLAIN WASHER 6	
11	140726000	1	ウフジ"クメタルM	UPPER SHAFT BUSH (M)	
13	152000001	1	ウフジ"クメタルF	UPPER SHAFT BUSH (F)	
14	013761412	1	トメネジ"5.95クホ"ミ	SET SCREW 5.95	
15	152231000	1	ツリアイクランク	COUNTER WEIGHT	
16	100250001	1	シメネジ"7.14	SCREW 7.14	
17	014770622	1	アナトメネジ"6.35クホ"ミ	SET SCREW 6.35	
18	101706001	1	トメネジ"6.35	SET SCREW 6.35	
19	014770622	1	アナトメネジ"6.35クホ"ミ	SET SCREW 6.35	
20	152232001	1	ハリホ"ウレンカクミ	THREAD TAKE-UP LEVER ASSEMBLY	
20-1	153330001	1	デンヒ"ンクミ	THREAD TAKE-UP ASSEMBLY	
20-2	152236001	1	デンヒ"ンササエシ"ク	THREAD TAKE-UP SUPPORT STUD	
20-3	152237001	1	ハリホ"ウクランク	NEEDLE BAR CRANK	
20-4	132051001	1	+ サラネジ"3.57L	SCREW 3.57L	
20-5	152238001	1	ハリホ"ウレンカン	THREAD TAKE-UP LEVER	
20-6	152239001	1	ハリホ"ウダ"キ	NEEDLE BAR CLAMP	
20-7	062680812	1	ナハ"コ437-40X8	SCREW 437X8	
21	013761412	1	トメネジ"5.95クホ"ミ	SET SCREW 5.95	
22	152240001	1	ハリホ"ウA	NEEDLE BAR (A)	
24	144458001	1	アタマツキトメネジ"3.57	SET SCREW 3.57	
25	152242001	1	ハリホ"ウメタルU	NEEDLE BAR BUSH (U)	
26	152243001	1	ハリホ"ウメタルD	NEEDLE BAR BUSH (D)	
27	*	1	ミシンハリDP	NEEDLE DP	
33	142211001	1	カクコマ	SLIDE BLOCK	
34	152244000	1	ハリホ"ウアンナイ	NEEDLE BAR GUIDE	
35	062781412	2	ナハ"コ635-28X14	SCREW 635X14	
36	116920001	1	オクリシ"クスラストリング"	THRUST RING	



D. 動車・遊車関係/Drive pulley and idler pulley mechanism/Antriebsriemenscheibe und Riemenscheibe/  
Mécánisme de poulie d'entraînement et poulie folle/Mecanismo de polea impulsora y polea tensora

REF.NO.	CODE	Q'TY	ヒンメイ	NAME OF PARTS	RMKS
1	153044001	1	ストップカムクミ	STOP CAM ASSEMBLY	
1-1	152693001	1	セイト"ウカムヘン	BRAKE CAM SEGMENT	
1-2	152694001	1	セイト"ウカムヘンバネ	SPRING	
1-3	115003001	1	カンシヨウカムヘン	FLANGE CAM SEGMENT	
1-4	153058001	2	カムヘンジ"ク	CAM SEGMENT STUD	
1-5	048040342	2	トメワE4	STOP RING E4	
7	147111001	1	テーパ"ピン6X35	TAPER PIN 6X35	
8	014770622	1	アナトメネシ"6.35クホ"ミ	SET SCREW 6.35	
9	183686001	1	プーリオオクミ	PULLEY DEVICE SET	
9-1	152695201	2	プーリクミ	PULLEY DEVICE ASSEMBLY	
9-2	072600760	2	タマシ"クウケ6007VV	BALL BEARING 6007VV	
9-3	152698001	1	スライト"メタル	SLIDE BUSH	
9-4	048350142	2	トメワシ"クヨウC35	STOP RING C35	
9-5	152699001	1	ナミワツシヤ	WASHER	
9-6	048240242	1	トメワアナヨウC24	STOP RING C24	
9-7	152700000	1	スライト"フ"ツシユA	SLIDE BUSH (A)	
17	151946000	1	スライト"フ"ツシユB	SLIDE BUSH (B)	
18	152701001	1	クラツチハン"バネ	SPRING	
19	152702001	1	クラツチハン	CLUTCH PLATE	
20	152703100	5	スペーサ	SPACER	
21	S02878000	1	ヘイコウキ3X3X13	KEY 3X3X13	
22	152705101	1	ナツト10ヒタ"リ	NUT 10	
23	152706001	1	ホ"ールウケ	BALL BEARING	
24	062660712	4	ナヘ"コ318-40X7	SCREW 318X7	
25	071095250	1	コウキユウ3/8	STEEL BALL 3/8"	
26	S21120001	1	サ"ガ"ネ	WASHER	

E. 補給部品/Supply parts/Lieferteile/Pièces fournies/Piezas de suministro

REF.NO.	CODE	Q'TY	ヒンメイ	NAME OF PARTS	RMKS
1	S01688001	1	ウワジ"ククミ430	UPPER SHAFT ASSEMBLY B430	

F. 送り関係/Feed mechanism/Transportvorrichtung/  
 Mécanisme de l'entraînement/Mecanismo de la alimentacion

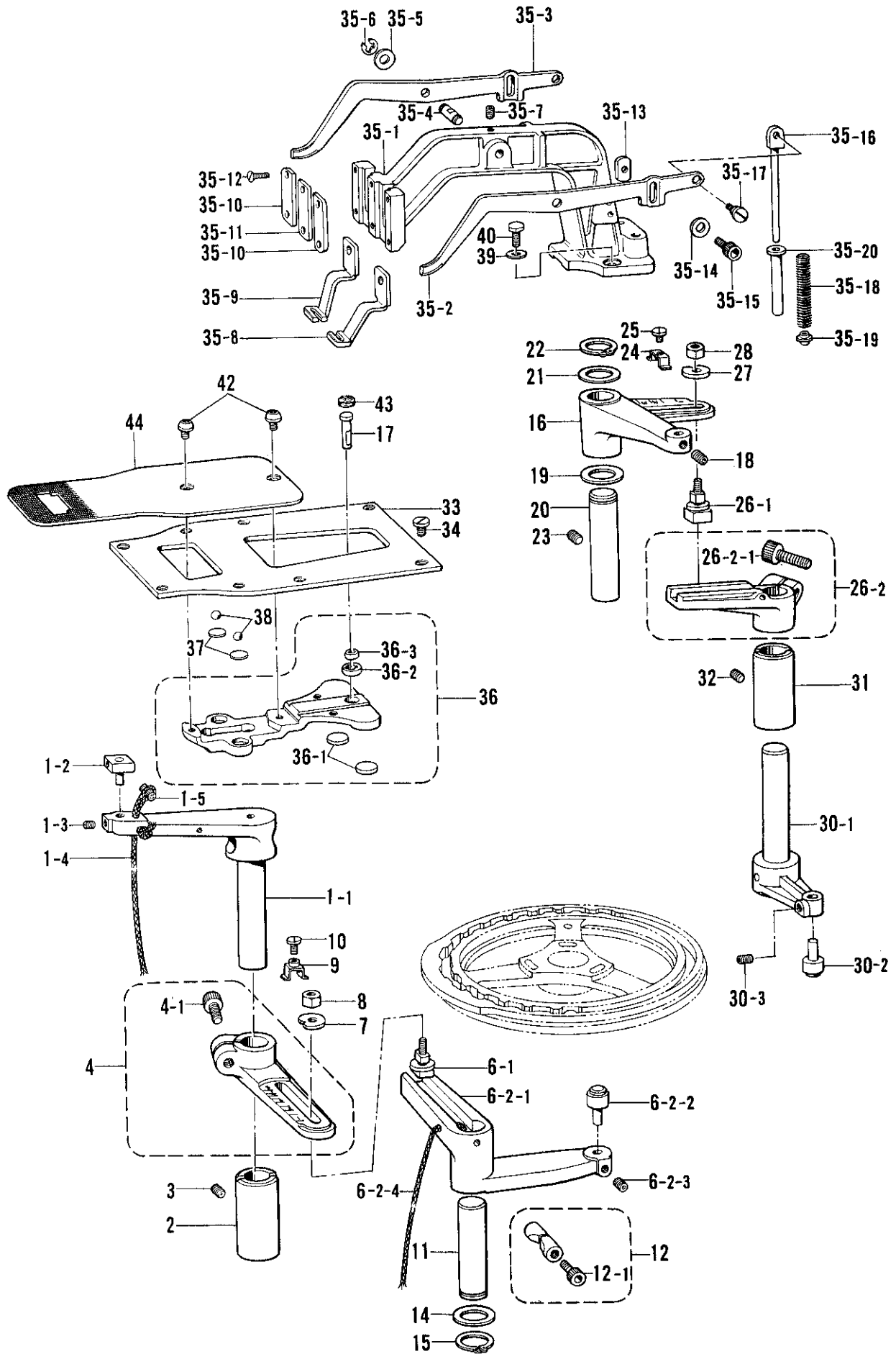

F. 送り関係/Feed mechanism/Transportvorrichtung/  
Mécanisme de l'entraînement/Mecanismo de la alimentacion

REF.NO.	CODE	Q'TY	ヒンメイ	NAME OF PARTS	RMKS
1	152741101	1	ヨコオクリレハ"ークミ	TACK LENGTH LEVER ASSEMBLY	
1-1	152742001	1	ヨコオクリレハ"	TACK LENGTH LEVER	
1-2	153041001	1	ヨコオクリカクゴ"マクミ	TACK LENGTH SLIDE BLOCK ASSEMBLY	
1-3	151602002	1	トメネジ"4.37	SET SCREW 4.37	
1-4	153924001	1	フェルト	FELT	
1-5	153921001	1	クミヒモ4X4 (L=150)	WICK 4X4 (L=150)	
2	152745001	1	オクリメタル	FEED BUSH	
3	014760622	1	アナトメネジ"5.95	SET SCREW 5.95	
4	153762101	1	ヨコチヨウセツレハ"ークミ	TACK LENGTH REGULATOR LEVER ASSEMBLY	
4-1	018082022	1	アナホ"ルト8X20	BOLT 8X20	
6	153047001	1	ヨコオクリチヨウセツクミ	TACK LENGTH REGULATOR ASSEMBLY	
6-1	153042001	1	オクリチヨウセツジ"ククミ	TACK ADJUST SHAFT ASSEMBLY	
6-2	152751101	1	ヨコオクリカムレハ"ークミ	SLIDE BLOCK ROLLER STUD ASSEMBLY	
6-2-1	152752001	1	ヨコオクリカムレハ"	TACK LENGTH LEVER	
6-2-2	153043001	1	オクリカムコロシ"ククミ	FEED CAM ROLLER SHAFT ASSEMBLY	
6-2-3	014760622	1	アナトメネジ"5.95	SET SCREW 5.95	
6-2-4	152980001	1	クミヒモ6X6 (L=150)	WICK 6X6 (L=150)	
7	152749001	1	オクリチヨウセツサ"ガ"ネ	FEED ADJUST WASHER	
8	152750001	1	オクリチヨウセツナツト	FEED ADJUST NUT	
9	153045001	1	オクリレハ"ーストツハ°	TACK LENGTH LEVER STOPPER	
10	105451002	1	シメネジ"3.57	SCREW 3.57	
11	152755001	1	ヨコオクリカムレハ"ーシ"ク	TACK LENGTH LEVER SHAFT	
12	S09132001	1	ピンチスリーブ"クミ	PINCH SLEEVE ASSEMBLY	
12-1	018063022	1	アナホ"ルト6X30	BOLT 6X30	
14	152756001	1	スラストサ"ガ"ネ18	THRUST WASHER 18	
15	048180142	1	トメワC18	STOP RING C18	
16	152758001	1	タテオクリレハ"	TACK WIDTH FEED LEVER	
17	152759001	1	タテオクリシ"ク	TACK WIDTH FEED SHAFT	
18	014760622	1	アナトメネジ"5.95	SET SCREW 5.95	
19	152756001	1	スラストサ"ガ"ネ18	THRUST WASHER 18	
20	152760001	1	タテオクリレハ"ーシ"ク	TACK WIDTH LEVER SHAFT	
21	152756001	1	スラストサ"ガ"ネ18	THRUST WASHER 18	
22	048180142	1	トメワC18	STOP RING C18	
23	014760622	1	アナトメネジ"5.95	SET SCREW 5.95	
24	153045001	1	オクリレハ"ーストツハ°	TACK LENGTH LEVER STOPPER	
25	105451002	1	シメネジ"3.57	SCREW 3.57	
26	153048001	1	タテオクリチヨウセツクミ	TACK WIDTH REGULATOR LEVER ASSEMBLY	
26-1	153042001	1	オクリチヨウセツジ"ククミ	TACK ADJUST SHAFT ASSEMBLY	
26-2	153757001	1	タテチヨウセツレハ"ークミ	TACK WIDTH ADJUST ASSEMBLY	
26-2-1	018082022	1	アナホ"ルト8X20	BOLT 8X20	
27	152749001	1	オクリチヨウセツサ"ガ"ネ	FEED ADJUST WASHER	
28	152750001	1	オクリチヨウセツナツト	FEED ADJUST NUT	
30	152762001	1	タテオクリカムレハ"ークミ	TACK LENGTH CAM LEVER ASSEMBLY	
30-1	153331001	1	タテオクリカムレハ"ーシ"ククミ	TACK WIDTH FEED SHAFT ASSEMBLY	
30-2	153043001	1	オクリカムコロシ"ククミ	FEED CAM ROLLER SHAFT ASSEMBLY	
30-3	014760622	1	アナトメネジ"5.95	SET SCREW 5.95	
31	152745001	1	オクリメタル	FEED BUSH	
32	014760622	1	アナトメネジ"5.95	SET SCREW 5.95	
33	152766001	1	オクリタ"イアンナイイタ	FEED BAR GUIDE PLATE	
34	145318001	8	シメネジ"4.37	SCREW 4.37	
35	*	1	オサエウテ"クミ	PRESSER ARM ASSEMBLY	
35-1	152768009	1	オサエウテ"	PRESSER ARM	
35-2	152774001	1	オサエウテ"レハ"ーミキ"	PRESSER ARM LEVER (R)	
35-3	152775001	1	オサエウテ"レハ"ーヒタ"リ	PRESSER ARM LEVER (L)	
35-4	152776001	1	オサエウテ"レハ"ーシ"ク	PRESSER ARM LEVER SHAFT	
35-5	143591001	2	スラストリング"	THRUST RING	
35-6	048050342	2	トメワE5	STOP RING E5	
35-7	014760622	1	アナトメネジ"5.95	SET SCREW 5.95	
35-8	*	1	オサエアシR	WORK CLAMP (R)	
35-9	*	1	オサエアシL	WORK CLAMP (L)	
35-10	152783001	2	オサエアシオサエイタA	WORK CLAMP GUIDE BRACKET (A)	
35-11	152784001	1	オサエアシオサエイタB	WORK CLAMP GUIDE BRACKET (B)	

F. 送り関係/Feed mechanism/Transportvorrichtung/  
 Mécanisme de l'entraînement/Mecanismo de la alimentacion

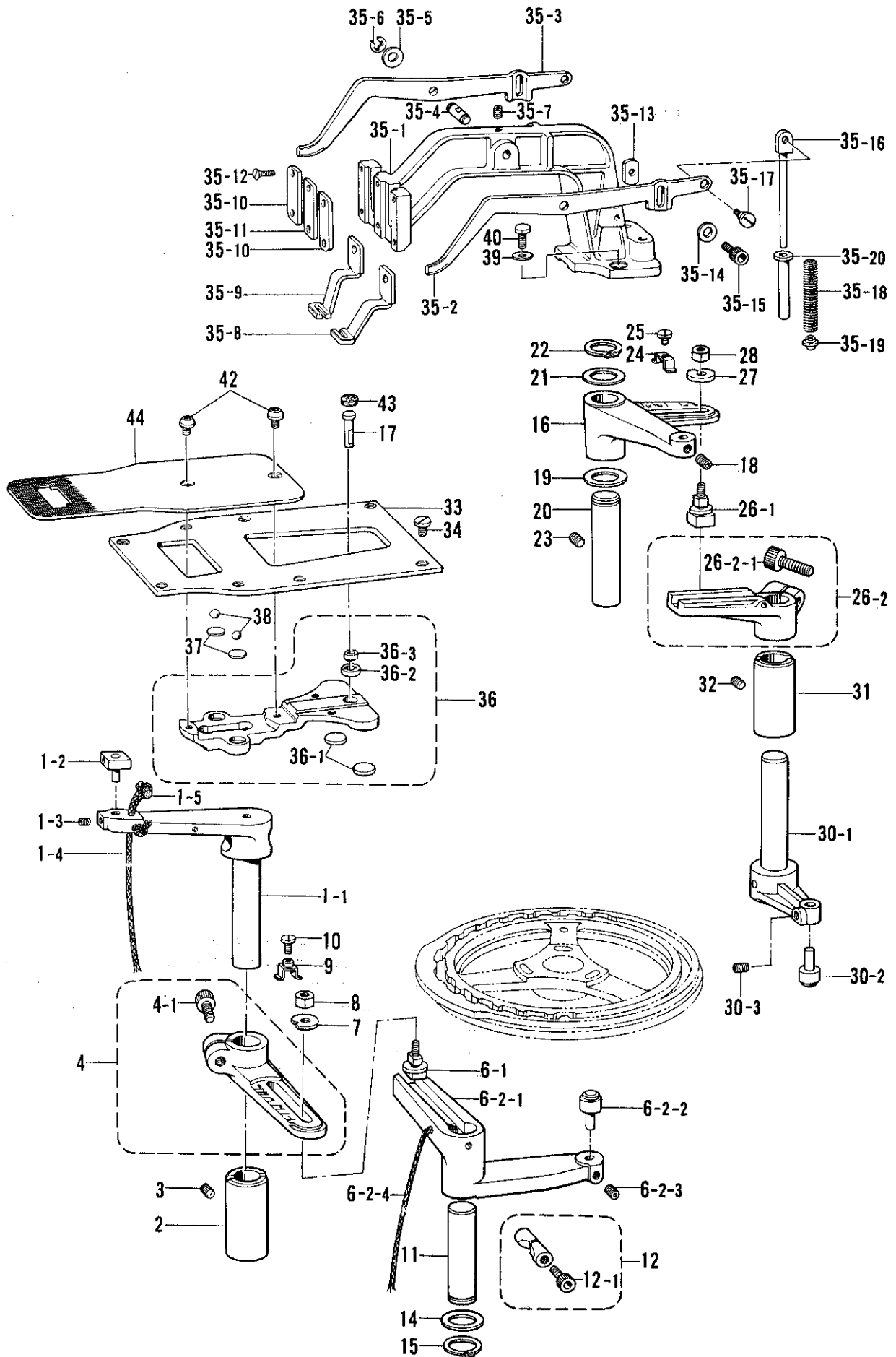

F. 送り関係/Feed mechanism/Transportvorrichtung/  
 Mécanisme de l'entraînement/Mecanismo de la alimentacion

REF.NO.	CODE	Q'TY	品名	NAME OF PARTS	RMKS
35-12	107038003	6	サラネジ"3.57	SCREW 3.57	
35-13	153571001	2	オサエウデ"レハ"ーイタ	PRESSER ARM LEVER PLATE	
35-14	140407002	2	サ"カ"ネ	WASHER	
35-15	018500822	2	アナホ"ルト5X8	BOLT 5X8	
35-16	153570001	2	オサエハ"ネアンナイロツト"	SPRING GUIDE ROD	
35-17	145478001	2	タ"ンネシ"4.76	STUD SCREW 4.76	
35-18	*	2	オサエハ"ネ	SPRING	
35-19	152788000	2	オサエハ"ネカンサ"	SPRING COLLAR	
35-20	153567000	2	オサエハ"ネカラー	SPRING COLLAR	
36	152769001	1	オクリダ"イクミ	FEED BAR GUIDE ASSEMBLY	
36-1	152771000	2	オクリダ"イカンサ"	COLLAR	
36-2	152773000	1	キユウメンブ"ツシユメタル	BUSH	
36-3	141331001	1	キユウメンブ"シユ	BUSH	
37	152772001	2	カンサ"	WASHER	
38	071047650	2	コウキユウ3/16	STEEL BALL 3/16"	
39	025060232	2	ヒラサ"カ"ネチユウ6	PLAIN WASHER 6	
40	017761412	2	ホ"ルト5.95X14	BOLT 5.95X14	
42	153057002	2	オクリイタシメネシ"	SCREW	
43	153035000	1	オサエウデ"フェルト	PRESSER ARM FELT	
44	*	1	オクリイタ	FEED PLATE	

G. 押工上げ関係 / Work clamp lifter mechanism / Stoffhalterhebevorrichtung /  
 Mécanisme de levreur du pinceur / Mecanismo del levantador de ménsula de trabajo

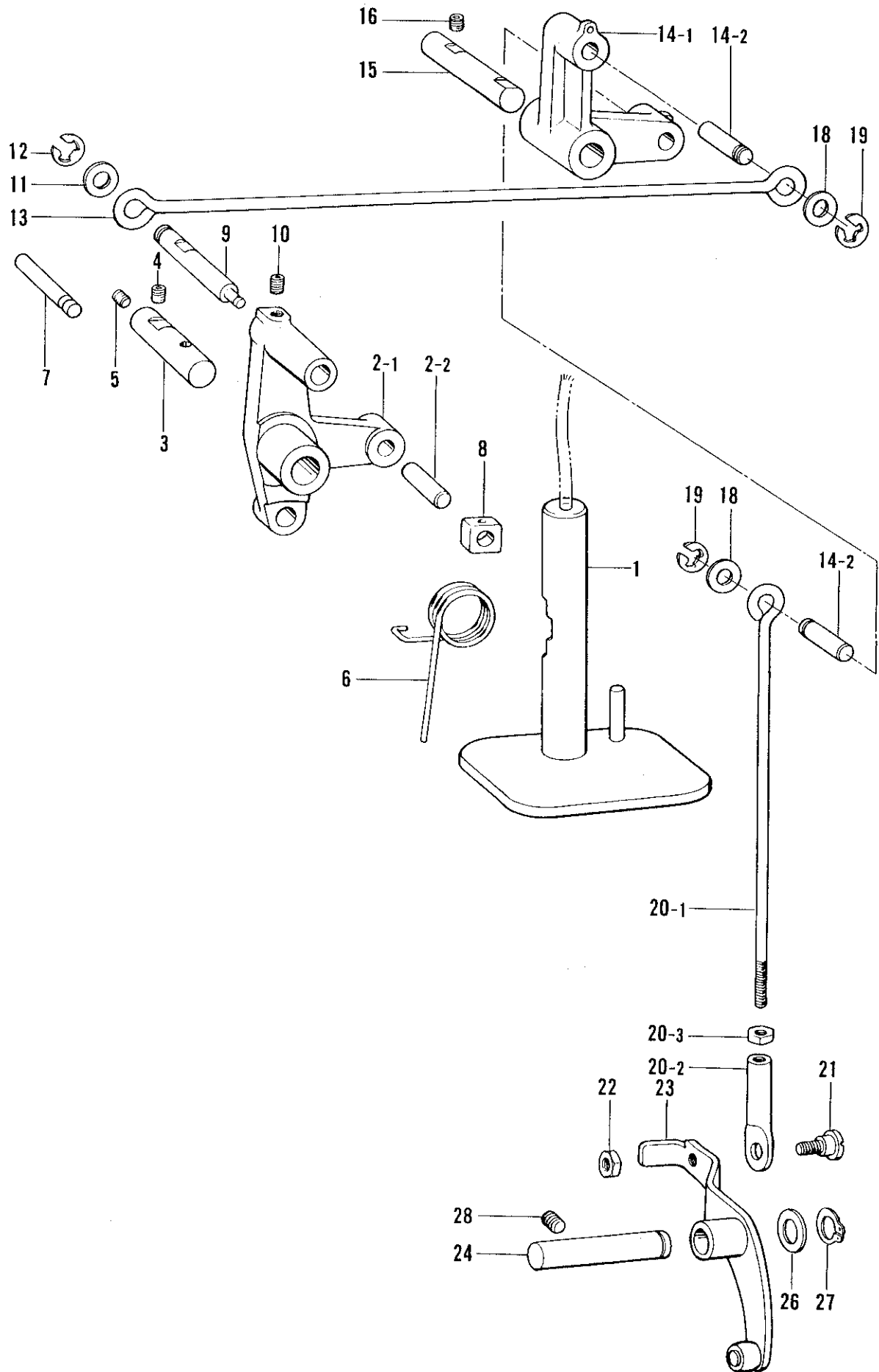



G. 押工上げ関係/Work clamp lifter mechanism/Stoffhalterhebevorrichtung/  
 Mécanisme de levreur du pinceur/Mecanismo del levantador de ménsula de trabajo

REF.NO.	CODE	Q'TY	ヒンメイ	NAME OF PARTS	RMKS
1	152794001	1	オサエアケ"イタクミ	WORK CLAMP LIFTER PLATE ASSEMBLY	
2	152797001	1	オサエアケ"レハ"ークミ	WORK CLAMP LIFTER LEVER ASSEMBLY	
2-1	152798001	1	オサエアケ"レハ"ー	WORK CLAMP LIFTER LEVER	
2-2	152744001	1	ヨコオクリカクゴ"マヒン	PIN	
3	152799001	1	オサエアケ"レハ"ー"シ"ク	WORK CLAMP LIFTER LEVER SHAFT	
4	014760622	1	アナトメネシ"5.95	SET SCREW 5.95	
5	013760612	1	トメネシ"5.95クホ"ミ	SET SCREW 5.95	
6	152800201	1	オサエアケ"ハ"ネ	SPRING	
7	152801001	1	ハ"ネカクヒン	PIN	
8	102630001	1	ハリホ"ウアンナイカクコマ	NEEDLE BAR GUIDE SLIDE BLOCK	
9	152802001	1	オサエアケ"ロツト"シ"クA	WORK CLAMP LIFTER ROD SHAFT (A)	
10	014760622	1	アナトメネシ"5.95	SET SCREW 5.95	
11	107153002	1	サ"カ"ネ	WASHER	
12	048060342	1	トメワE6	STOP RING E6	
13	152803001	1	オサエアケ"ロツト"A	WORK CLAMP LIFTER ROD (A)	
14-1	152805101	1	オサエアケ"レンケツレハ"ー	CONNECTING LEVER	
14-2	152806001	2	オサエアケ"ロツト"シ"クB	CONNECTING LEVER SHAFT (B)	
15	158686001	1	レンケツレハ"ー"シ"ク	LIFTING LEVER SHAFT	
16	014760622	1	アナトメネシ"5.95	SET SCREW 5.95	
18	107153002	2	サ"カ"ネ	WASHER	
19	048060342	2	トメワE6	STOP RING E6	
20	152808101	1	チヨウセツロツト"クミ	ADJUST ROD ASSEMBLY	
20-1	154332001	1	オサエアケ"チヨウセツロツト"	PRESSER BAR LIFTER ADJUST ROD	
20-2	154333001	1	オサエアケ"チヨウセツツキ"テ	PRESSER BAR LIFTER ADJUST JOINT	
20-3	150556001	1	ナツト6.35	NUT 6.35	
21	141583001	1	タ"ンネシ"6.35	STUD SCREW 6.35	
22	150556001	1	ナツト6.35	NUT 6.35	
23	152811001	1	サト"ウレハ"ークミ	CONNECTING LEVER ASSEMBLY	
24	158687001	1	サト"ウレハ"ー"シ"ク	DRIVING SHAFT	
26	142628001	1	スイヘイオクリクランクリング"	FEED ROCK CRANK RING	
27	048110142	1	トメワシ"クヨウC11	STOP RING C11	
28	014760622	1	アナトメネシ"5.95	SET SCREW 5.95	

H. カム伝導関係/Vertical shaft mechanism/Vertikale Welle/  
 Mécanisme d'arbre vertical/Mecanismo de eje vertical

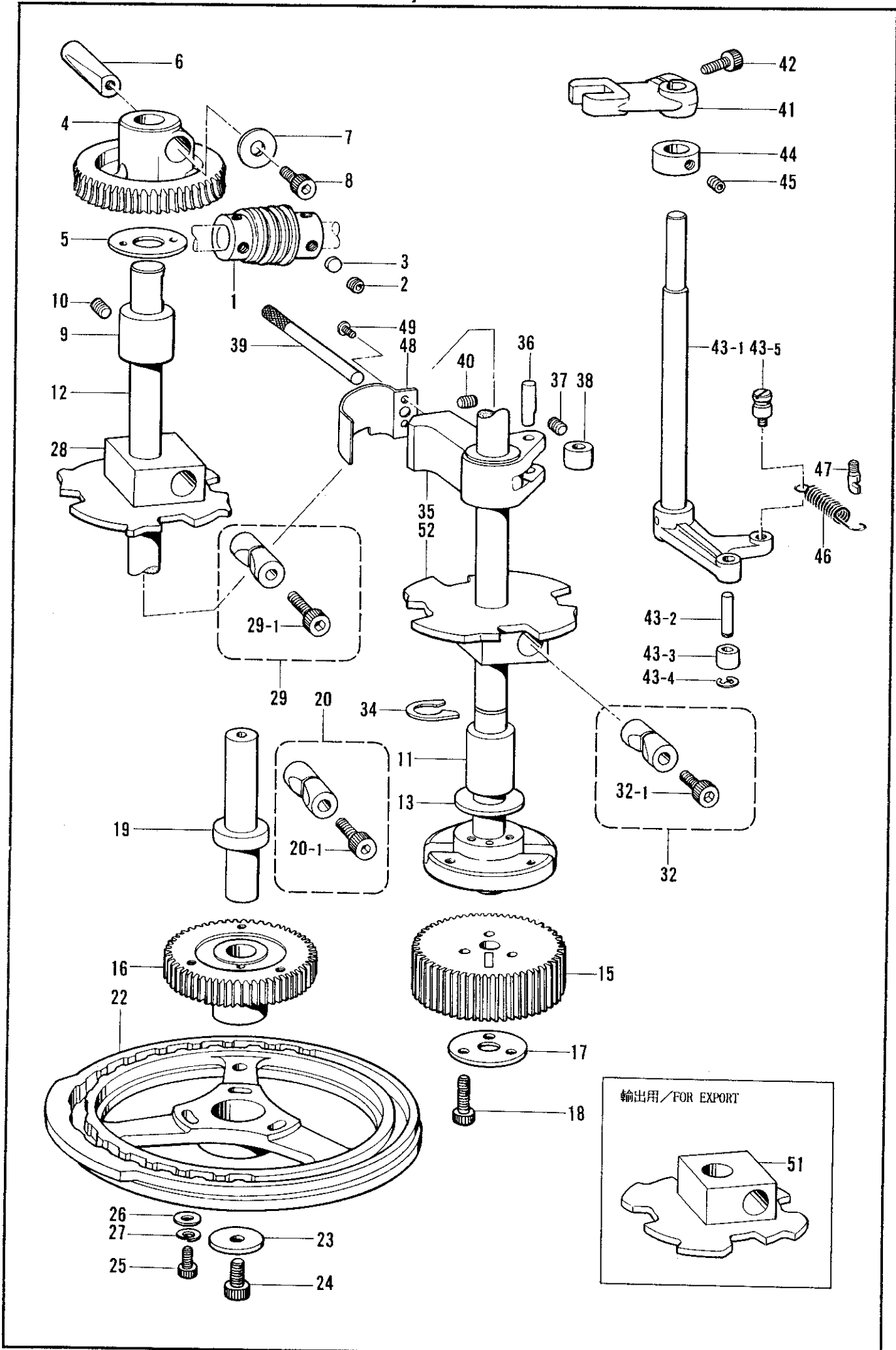

H. カム伝導関係/Vertical shaft mechanism/Vertikale Welle/  
Mécanisme d'arbre vertical/Mecanismo de eje vertical

REF.NO.	CODE	Q'TY	ヒンメイ	NAME OF PARTS	RMKS
1	152707001	1	ウオーム	WORM	
2	152718001	6	アナトメネジ"5.95	SET SCREW 5.95	
3	147151000	1	トメサ"ガ"ネ	WASHER	
4	152708000	1	ウオームホイール	WORM WHEEL	
5	152713001	1	スラストサ"ガ"ネ	THRUST WASHER	
6	152709000	1	スリーブ"	SLEEVE	
7	152710001	1	サ"ガ"ネ	WASHER	
8	018062022	1	アナボ"ルト6X20	BOLT 6X20	
9	159977000	1	タテシ"クメタルU	VERTICAL SHAFT BUSH (U)	
10	014760622	1	アナトメネジ"5.95	SET SCREW 5.95	
11	159978001	1	タテシ"クメタルL	VERTICAL SHAFT BUSH (L)	
12	159979001	1	タテシ"クソウクミ	VERTICAL SHAFT ASSEMBLY	
13	159984001	1	スラストサ"ガ"ネ40	THRUST WASHER 40	
15	*	1	チエンシ"キ"ヤ W	CHANGE GEAR (W)	
16	*	1	チエンシ"キ"ヤ C	CHANGE GEAR (C)	
17	153104001	1	チエンシ"キ"ヤサ"ガ"ネ	WASHER	
18	018062222	3	アナボ"ルト6X22	BOLT 6X22	
19	152724001	1	カムシ"ク	TACK LENGTH FEED CAM SHAFT	
20	S09132001	1	ピンチスリーブ"クミ	PINCH SLEEVE ASSEMBLY	
20-1	018063022	1	アナボ"ルト6X30	BOLT 6X30	
22	*	1	オクリカム	FEED CAM	
23	152728001	1	スラストサ"ガ"ネ8	THRUST WASHER 8	
24	151163001	1	アナボ"ルト8X15	BOLT 8X15	
25	018062022	3	アナボ"ルト6X20	BOLT 6X20	
26	109893002	3	サ"ガ"ネ	WASHER	
27	028060242	3	ハ"ネサ"ガ"ネ2-6	SPRING WASHER 2-6	
28	152729001	1	クラツチカム	-----	
29	S09132001	1	ピンチスリーブ"クミ	PINCH SLEEVE ASSEMBLY	
29-1	018063022	1	アナボ"ルト6X30	BOLT 6X30	
32	S09132001	1	ピンチスリーブ"クミ	PINCH SLEEVE ASSEMBLY	
32-1	018063022	1	アナボ"ルト6X30	BOLT 6X30	
34	152723001	1	イトキリカムトメリング"	STOP RING	
35	152731001	1	セイキ"ヨタイ	ROLLER HOLDER	
36	152732001	1	セイキ"ヨタイコロシ"ク	ROLLER SHAFT	
37	013710712	1	トメネジ"4.76クボ"ミ	SET SCREW 4.76	
38	152914001	1	コロ	ROLLER	
39	152733001	1	ヒシ"ヨウテイシレハ"ー	EMERGENCY STOP LEVER	
40	013710712	1	トメネジ"4.76クボ"ミ	SET SCREW 4.76	
41	152734001	1	セイキ"ヨレハ"ー	ROLLER HOLDER LEVER	
42	018061622	1	アナボ"ルト6X16	BOLT 6X16	
43	152735101	1	セイキ"ヨカムレハ"ークミ	ROLLER HOLDER CAM LEVER ASSEMBLY	
43-1	153332001	1	セイキ"ヨカムレハ"ーシ"ククミ	ROLLER HOLDER CAM LEVER SHAFT ASSEMBLY	
43-2	152739001	1	コロシ"ク	ROLLER SHAFT	
43-3	153195001	1	コロ	ROLLER	
43-4	048040342	1	トメフE4	STOP RING E4	
43-5	155337001	1	ハ"ネカケ	SPRING HOOK	
44	110027001	1	ゼツトカラー	SET COLLAR	
45	014760622	2	アナトメネジ"5.95	SET SCREW 5.95	
46	155336001	1	セイキ"ヨハ"ネ	SPRING	
47	141334001	1	ハ"ネカケ	SPRING HOOK	
48	153141001	1	セイキ"ヨタイカハ"ー	ROLLER HOLDER COVER	
49	062670412	2	ナヘ"コ357-40X4	SCREW 357X4	
51	S07813001	1	-----	CLUTCH CAM (SP)	
52	S07814001	1	イトキリカムSP	KNIFE CAM (SP)	

J. パワー押エ関係/Power lift mechanism/Heberbetätigungsverrichtung/  
 Mécanisme de leveur/Mecanismo de carrera de potencia

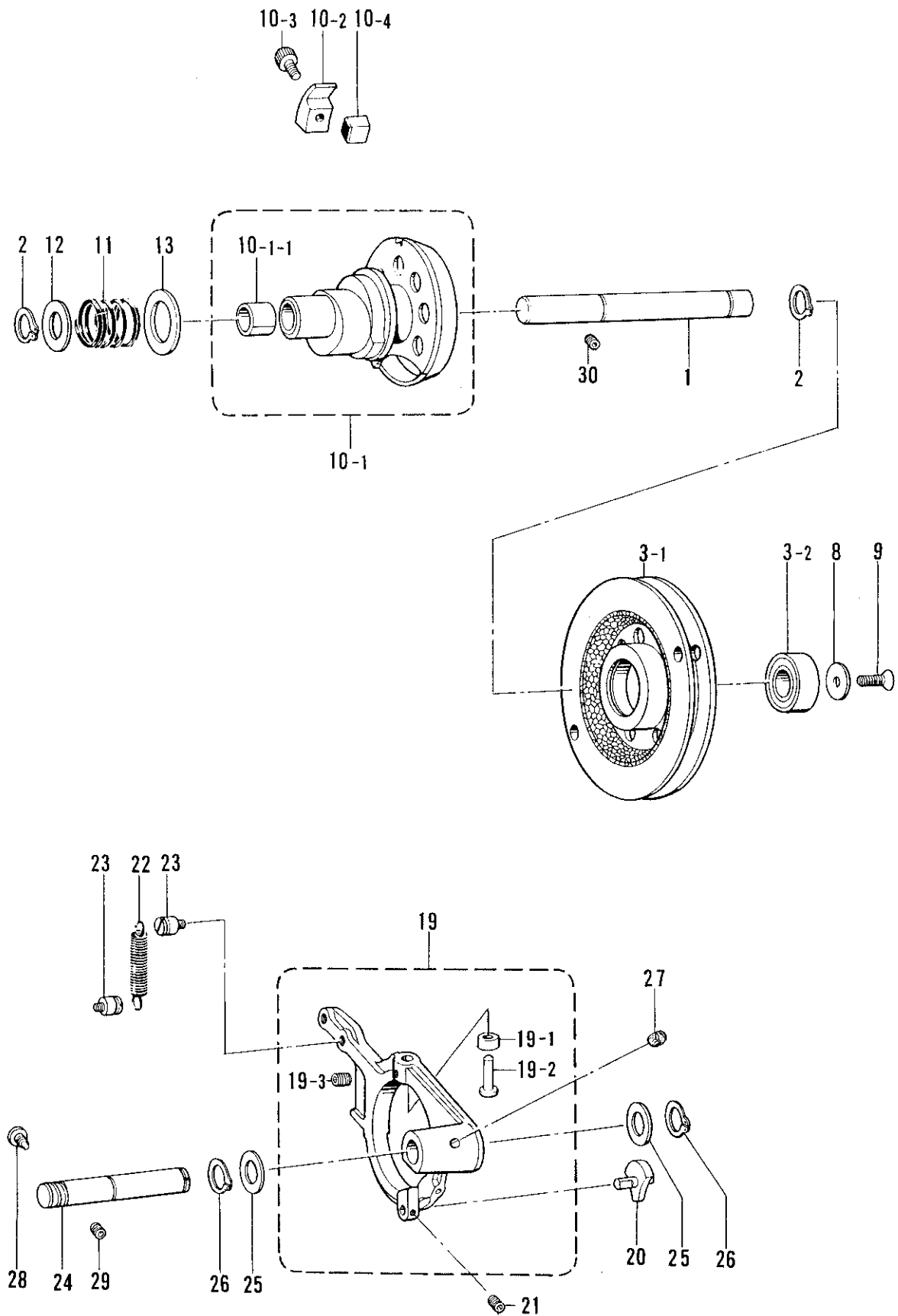

J. パワー押工関係/Power lift mechanism/Heberbetätigungsvo­rrichtung/  
Méc­anisme de le­veur/Mecanismo de carrera de potencia

REF.NO.	CODE	Q'TY	ヒンメイ	NAME OF PARTS	RMKS
1	151928001	1	Pプーリシク	POWER PULLEY SHAFT	
2	048170142	2	トメワシクヨウC17	STOP RING C17	
3	156936101	1	Pプーリソウクミ	POWER PULLEY ASSEMBLY	
3-1	151930201	1	Pプーリクミ	POWER PULLEY ASSEMBLY	
3-2	072600360	1	タマシクウケ6003VV	BALL BEARING 6003VV	
8	151932001	1	シクウケフタ	BEARING COVER	
9	107231002	1	サラネシ"4.76	SCREW 4.76	
10	*	1	ハワーカムセット	POWER CAM SET	
10-1	*	1	ハワーカムクミ	POWER CAM ASSEMBLY	
10-1-1	151935000	2	DVブツシユ	(DV) BUSH	
10-2	151940001	1	ハワーカムストツハ°A	POWER CAM STOPPER (A)	
10-3	018060822	1	アナホルト6X8	BOLT 6X8	
10-4	151941101	1	ハワーカムストツハ°Bクミ	POWER CAM STOPPER (B) ASSEMBLY	
11	151936001	1	Pクラツチハネ	SPRING	
12	151937001	1	スラストサ"ガ"ネ17	THRUST WASHER 17	
13	151938001	1	サ"ガ"ネ	WASHER	
19	151944001	1	クト"ーレハ"ークミ	CLUTCH ACTUATING LEVER ASSEMBLY	
19-1	151947101	2	コロ11	ROLLER (11)	
19-2	151948001	2	クト"ーレハ"ーコロシク	ROLLER SHAFT	
19-3	014760622	2	アナトメネシ"5.95	SET SCREW 5.95	
20	151949001	1	オサエアケ"コロシククミ	ROLLER SHAFT ASSEMBLY	
21	014760622	1	アナトメネシ"5.95	SET SCREW 5.95	
22	151951001	1	クト"ーレハ"ーヒキハネ	SPRING	
23	141472002	2	シタイトキリレハ"ーハ"ネカケ	SPRING HOOK	
24	151952001	1	クト"ーレハ"ーシク	CLUTCH ACTUATING LEVER SHAFT	
25	151953001	2	スラストサ"ガ"ネ16	THRUST WASHER 16	
26	048160142	2	トメワシクヨウC16	STOP RING C16	
27	107149001	1	フェルト	FELT	
28	151954001	1	アンナイヒ"ンネシ"	SCREW	
29	014821022	1	アナトメネシ"7.94クホ"ミ	SET SCREW 7.94	
30	014760622	1	アナトメネシ"5.95	SET SCREW 5.95	

K. 下軸関係 / Lower shaft mechanism / Untere Welle /  
 Mécanisme de l'arbre inférieur / Mecanismo del eje inferior

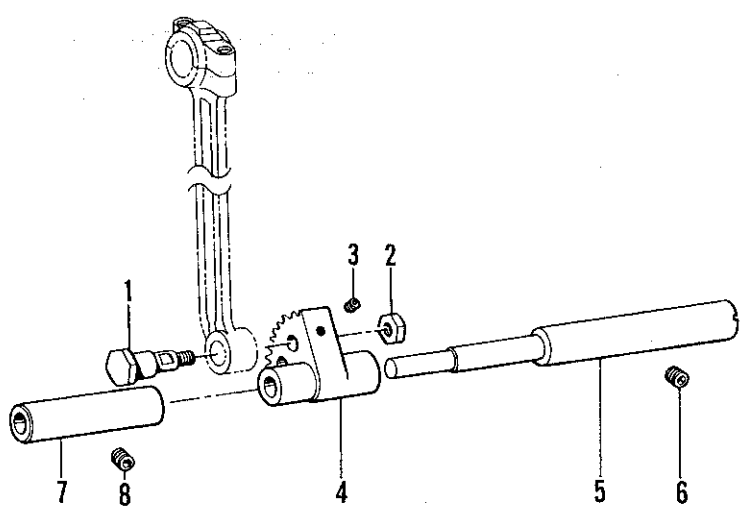
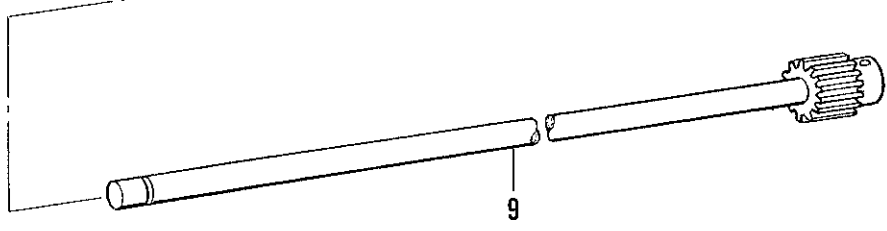
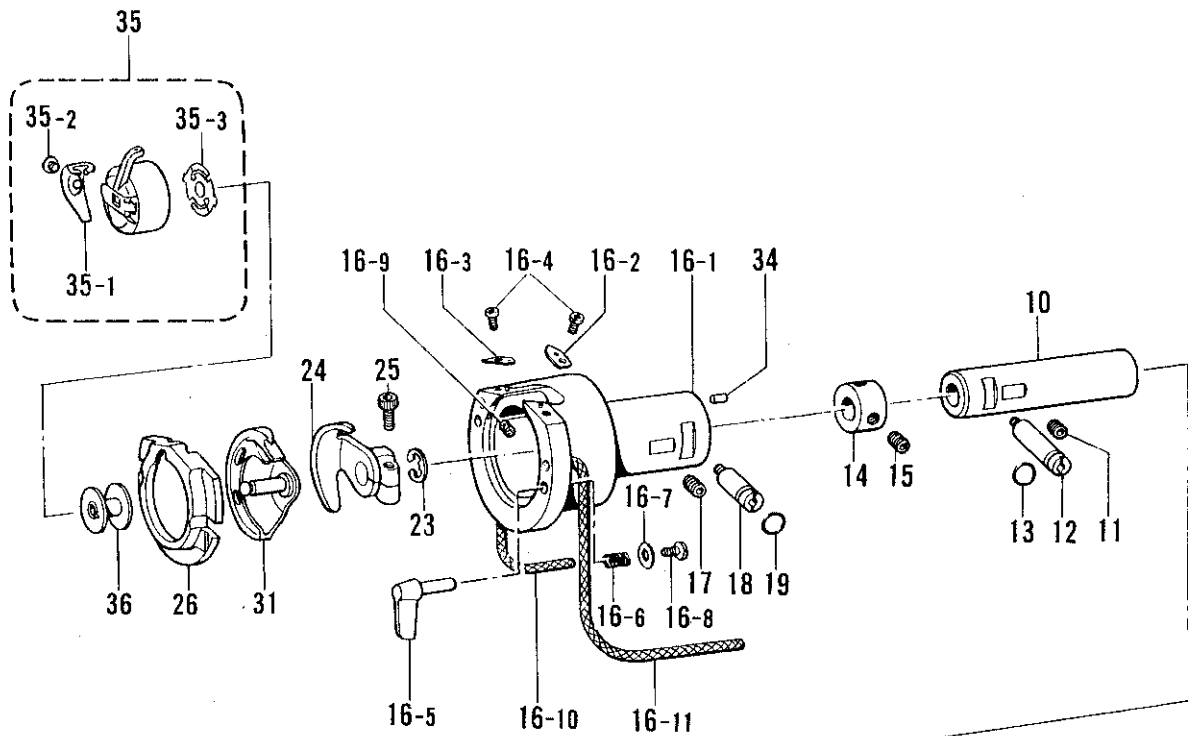

K. 下軸関係 / Lower shaft mechanism / Untere Welle /  
Mécanisme de l'arbre inférieur / Mecanismo del eje inferior

REF.NO.	CODE	Q'TY	品名	NAME OF PARTS	RMKS
1	141786001	1	クランクロッド"タ"ネジ	CRANK ROD STUD SCREW	
2	104689002	1	ナット7.14	NUT 7.14	
3	014680622	1	アナトメネジ"4.37クホ"ミ	SET SCREW 4.37	
4	152245001	1	ヨウト"ウキ"ヤ	ROCK GEAR	
5	152246001	1	ヨウト"ウキ"ヤ"シ"ク	ROCK GEAR SHAFT	
6	014760622	1	アナトメネジ"5.95	SET SCREW 5.95	
7	152247001	1	ヨウト"ウシ"クメタル	ROCK SHAFT BUSH	
8	014760622	1	アナトメネジ"5.95	SET SCREW 5.95	
9	152191101	1	シタジ"ククミ	LOWER SHAFT ASSEMBLY	
10	152250001	1	シタジ"クメタル	LOWER SHAFT BUSH	
11	014760622	1	アナトメネジ"5.95	SET SCREW 5.95	
12	152678001	1	カマチヨウセツシ"ク	SHUTTLE HOOK ADJUST STUD	
13	081003670	1	Oリング"PW3	O RING PW3	
14	110495003	1	セツトカラー	SET COLLAR	
15	014770622	2	アナトメネジ"6.35クホ"ミ	SET SCREW 6.35	
16	S00327001	1	オオカマタイクミ	SHUTTLE RACE BASE ASSEMBLY	
16-1	152677001	1	オオカマタイ	SHUTTLE RACE BASE	
16-2	152679001	1	カマイトアンナイR	SHUTTLE RACE THREAD GUIDE (R)	
16-3	152680001	1	カマイトアンナイL	SHUTTLE RACE THREAD GUIDE (L)	
16-4	062660412	2	ナヘ"コ318-40X4	SCREW 318X4	
16-5	152683001	2	オオカマトリツケツメ	LARGE SHUTTLE HOOK SET CLAW	
16-6	152684001	2	オオカマトリツケハ"ネ	SPRING	
16-7	402887001	2	サ"ガ"ネ3.2	WASHER 3.2	
16-8	062660712	2	ナヘ"コ318-40X7	SCREW 318X7	
16-9	153050000	2	オオカマタイフェルト	SHUTTLE RACE BASE FELT	
16-10	155489000	1	クミヒモ (L=270)	WICK (L=270)	
16-11	S00400000	1	クミヒモ2.5X220	WICK 2.5X220	
17	014760622	1	アナトメネジ"5.95	SET SCREW 5.95	
18	152678001	1	カマチヨウセツシ"ク	SHUTTLE HOOK ADJUST STUD	
19	081003670	1	Oリング"PW3	O RING PW3	
23	048080342	1	トメワE8	STOP RING E8	
24	152681201	1	ドライバ"ー	DRIVER	
25	018501422	1	アナボ"ルト5X14	BOLT 5X14	
26	*	1	オオカマ	LARGE SHUTTLE HOOK	
31	*	1	ナカカマ	INNER ROTARY HOOK	
34	141808001	1	オオカマアンナイピン	PIN	
35	159610101	1	ボ"ビ"ンケースクミA	BOBBIN CASE ASSEMBLY (A)	
35-1	154339001	1	ボ"ビ"ンケースチヨウシハ"ネ	TENSION SPRING	
35-2	154341001	1	ボ"ビ"ンケースハ"ネネジ	SCREW	
35-3	159612001	1	クウテンボ"ウシハ"ネ	BOBBIN TENSION SPRING	
36	159613001	1	ボ"ビ"ン	BOBBIN	

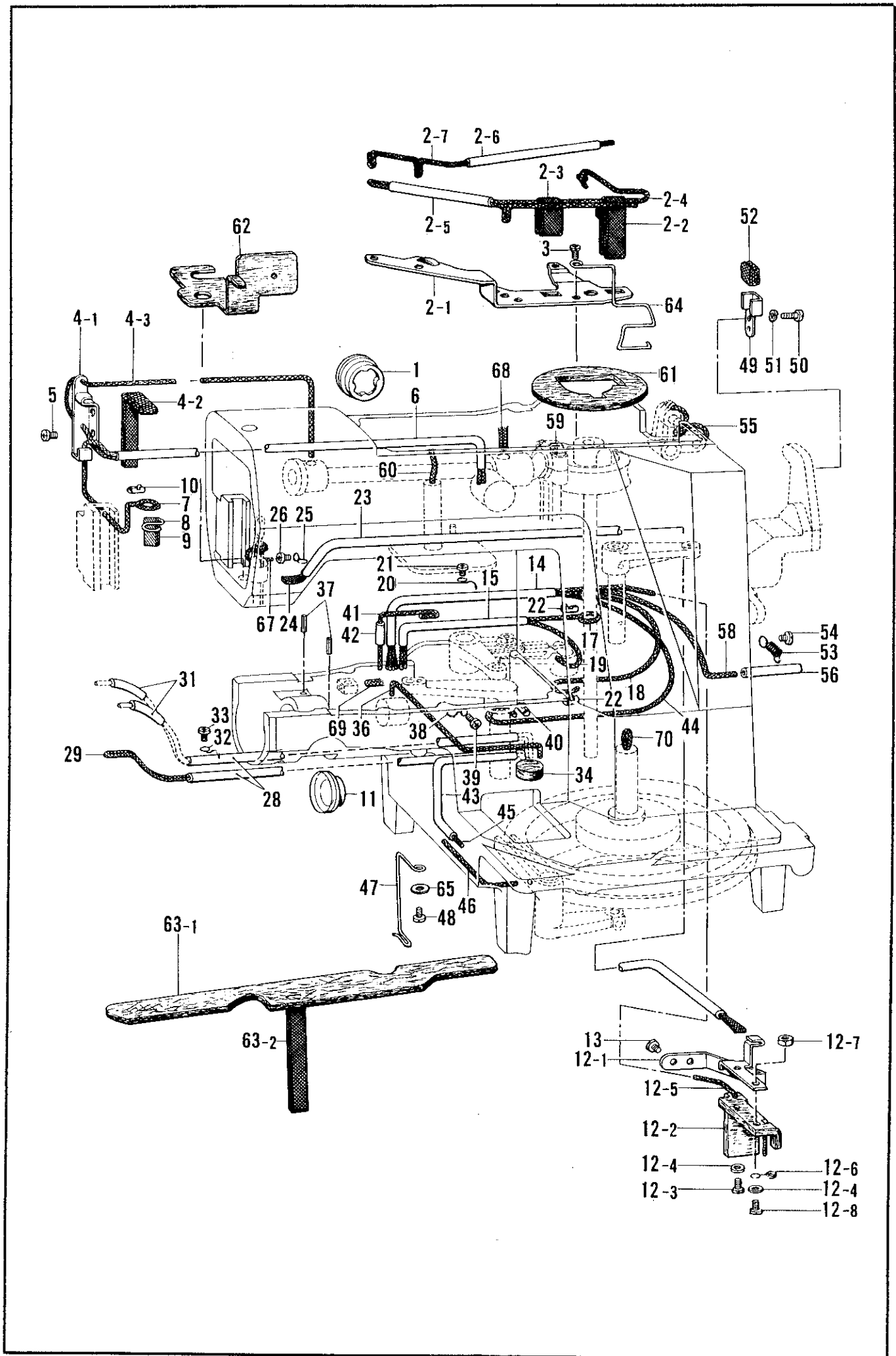



## L. 給油潤滑関係/Lubrication/Schmierung/Lubrification/Lubricación

REF.NO.	CODE	Q'TY	ヒンメイ	NAME OF PARTS	RMKS
1	152948001	1	オイルホ"ツトマト"	OIL GAUGE WINDOW	
2	152949001	1	ウフジ"クキユウユササエクミ	WICK SUPPORT ASSEMBLY	
2-1	152950001	1	ウフジ"クキユウユササエ	WICK SUPPORT	
2-2	152951001	1	ウオームキユウユフエルト	FELT	
2-3	152952001	1	ロツト"キユウユフエルト	FELT	
2-4	153918001	1	クミヒモ6X6 (L=660)	WICK 6X6 (L=660)	
2-5	140423000	1	ヒ"ニルチューブ"	OIL TUBE	
2-6	147745000	1	ハイユパイプ" L	OIL TUBE (L)	
2-7	153919001	1	クミヒモ6X6 (L=370)	WICK 6X6 (L=370)	
3	062680812	2	ナヘ"コ437-40X8	SCREW 437X8	
4	152958001	1	デンヒン"キユウユササエクミ	WICK SUPPORT ASSEMBLY	
4-1	152959001	1	デンヒン"キユウユササエ	WICK SUPPORT	
4-2	152955001	1	ヒラクミヒモ (L=210)	FLAT WICK (L=210)	
4-3	152956001	1	クミヒモ4X4 (L=500)	WICK 4X4 (L=500)	
5	062680612	1	ナヘ"コ4.37-40X6	SCREW 437X6	
6	144694001	1	ハイユパイプ"	OIL TUBE	
7	152956001	1	クミヒモ4X4 (L=500)	WICK 4X4 (L=500)	
8	152962001	1	ハリホ"ウメタルヒモササエ	WICK SUPPORT	
9	152960001	1	ヒラクミヒモ (L=40)	FLAT WICK (L=40)	
10	104567001	1	クミヒモササエ	WICK SUPPORT	
11	152948001	1	オイルホ"ツトマト"	OIL GAUGE WINDOW	
12	152961001	1	シタジ"クキユウユササエクミ	FELT SUPPORT ASSEMBLY	
12-1	152966001	1	シタジ"クキユウユササエ	FELT SUPPORT	
12-2	152967001	1	シタジ"クキユウユフエルト	FELT	
12-3	062670812	2	ナヘ"コ357-40X8	SCREW 357X8	
12-4	025350332	3	ヒラザ"ガ"ネタ"イ3.5	PLAIN WASHER 3.5	
12-5	152963001	1	クミヒモ4X4 (L=600)	WICK 4X4 (L=600)	
12-6	141692001	1	ヒ"ニルチューブ"ササエC	OIL SUPPORT (C)	
12-7	021670202	1	ナツト2シユ3.57	NUT 3.57	
12-8	062671412	1	ナヘ"コ357-40X14	SCREW 357X14	
13	062670612	2	ナヘ"コ357-40X6	SCREW 357X6	
14	148921000	1	ヒ"ニルチューブ"	OIL TUBE	
15	147745000	1	ハイユパイプ" L	OIL TUBE (L)	
17	152964001	1	クミヒモ6X6 (L=310)	WICK 6X6 (L=310)	
18	152965001	1	クミヒモ4X4 (L=400)	WICK 4X4 (L=400)	
19	152964001	1	クミヒモ6X6 (L=310)	WICK 6X6 (L=310)	
20	152969001	1	コード"ササエカネ	CORD SUPPORT	
21	062670512	1	ナヘ"コ357-40X5	SCREW 357X5	
22	104567001	2	クミヒモササエ	WICK SUPPORT	
23	146375000	1	ヒ"ニルチューブ"	OIL TUBE	
24	152992001	1	ヒラクミヒモ (L=760)	FLAT WICK (L=760)	
25	117150001	1	コード"ササエカネ	CORD SUPPORT	
26	062670512	1	ナヘ"コ357-40X5	SCREW 357X5	
28	140423000	2	ヒ"ニルチューブ"	OIL TUBE	
29	152971001	1	クミヒモ4X4 (L=480)	WICK 4X4 (L=480)	
31	112669001	2	ヒ"ニルチューブ"	OIL TUBE	
32	152969001	1	コード"ササエカネ	CORD SUPPORT	
33	062670512	1	ナヘ"コ357-40X5	SCREW 357X5	
34	113006001	1	フェルト	FELT	
36	152973001	1	クミヒモ4X4 (L=170)	WICK 4X4 (L=170)	
37	047251640	2	スプリング"ピンAW2.5	SPRING PIN AW2.5	
38	117150001	1	コード"ササエカネ	CORD SUPPORT	
39	062670512	1	ナヘ"コ357-40X5	SCREW 357X5	
40	104567001	1	クミヒモササエ	WICK SUPPORT	
41	152974001	1	クミヒモ4X4 (L=350)	WICK 4X4 (L=350)	
42	112669001	1	ヒ"ニルチューブ"	OIL TUBE	
43	147745000	1	ハイユパイプ" L	OIL TUBE (L)	
44	153922001	1	クミヒモ4X4 (L=500)	WICK 4X4 (L=500)	
45	152953001	1	クミヒモ6X6 (L=360)	WICK 6X6 (L=360)	
46	152985001	1	クミヒモ4X4 (L=120)	WICK 4X4 (L=120)	
47	153763001	1	キユウユヒモササエ	WICK SUPPORT	
48	062670512	1	ナヘ"コ357-40X5	SCREW 357X5	

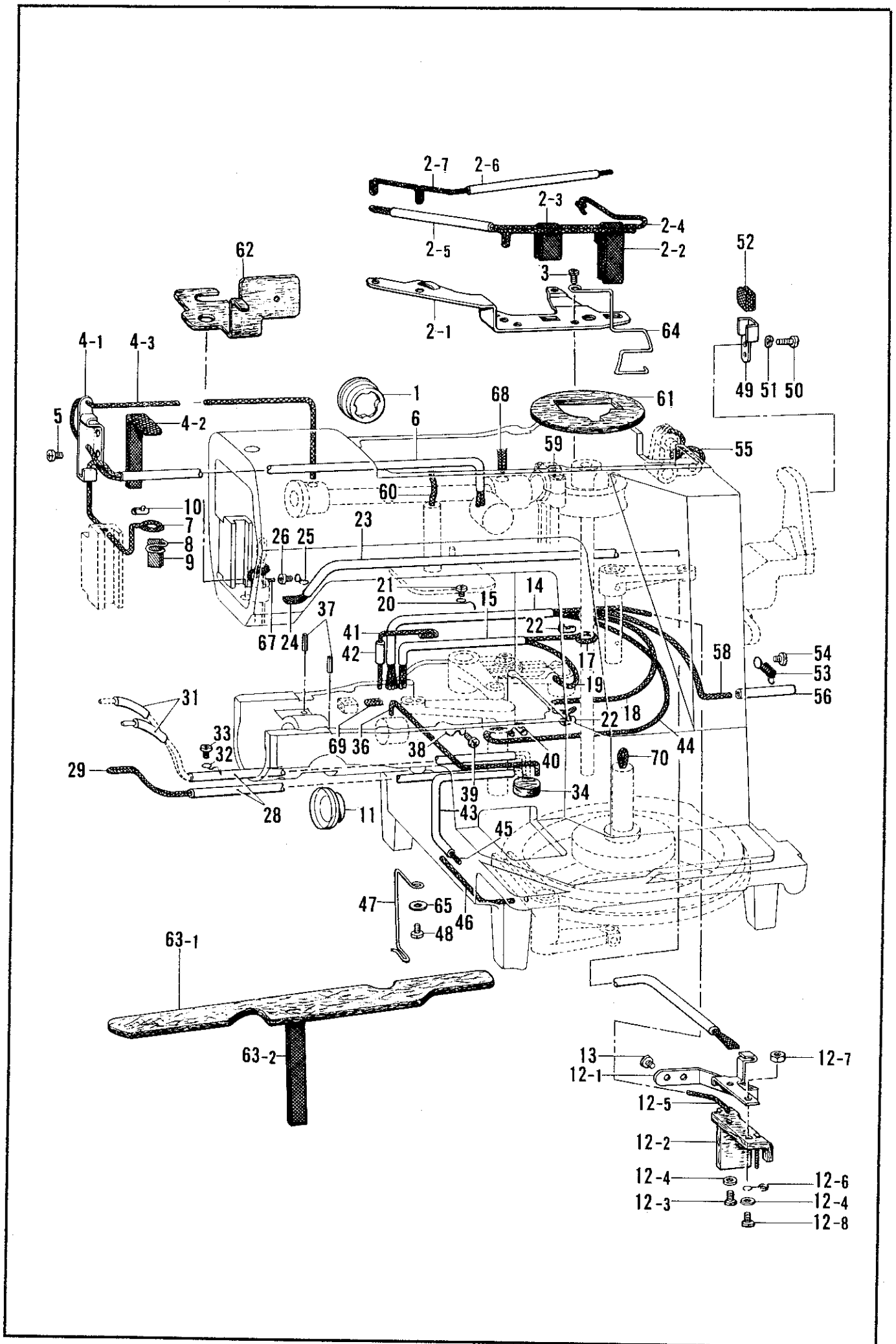

L. 給油潤滑関係/Lubrication/Schmierung/Lubrification/Lubricación

REF.NO.	CODE	Q'TY	品名	NAME OF PARTS	RMKS
49	152976001	1	ホイルキユウヒモササエ	WICK SUPPORT	
50	062670512	2	ナヘコ357-40X5	SCREW 357X5	
51	028040242	2	ハネサガネ2-4	SPRING WASHER 2-4	
52	152977001	1	ヒラクミヒモ (L=50)	WICK (L=50)	
53	152978001	1	チューブ"オサエ	TUBE SUPPORT	
54	062680812	1	ナヘコ437-40X8	SCREW 437X8	
55	153927001	1	クミヒモ6X6 (L=180)	WICK 6X6 (L=180)	
56	112669001	1	ビニルチューブ	OIL TUBE	
58	153922001	1	クミヒモ4X4 (L=500)	WICK 4X4 (L=500)	
59	107149001	1	フェルト	FELT	
60	152968001	1	クミヒモ4X4 (L=100)	WICK 4X4 (L=100)	
61	153529101	1	ホイルキユウフェルト	FELT	
62	153530001	1	スライダ"フェルト	FELT	
63-1	153531001	1	ベッド"Lフェルト	BED (L) FELT	
63-2	153562001	1	ヒラクミヒモ (L=150)	FLAT WICK (L=150)	
64	153528001	1	ウオームキユウフェルトササエ	FELT SUPPORT	
65	105248003	1	サガネ	WASHER	
67	152973001	1	クミヒモ4X4 (L=170)	WICK 4X4 (L=170)	
68	153925001	1	クミヒモ4X4 (L=30)	WICK 4X4 (L=30)	
69	153926001	1	タコヒモ (L=10)	WICK (L=10)	
70	152980001	1	クミヒモ6X6 (L=150)	WICK 6X6 (L=150)	

M. 糸通シ関係 / Threading mechanism / Fadenführungs-vorrichtung /  
 Mécanisme de l'enfilage / Mecanismo del enhebrado

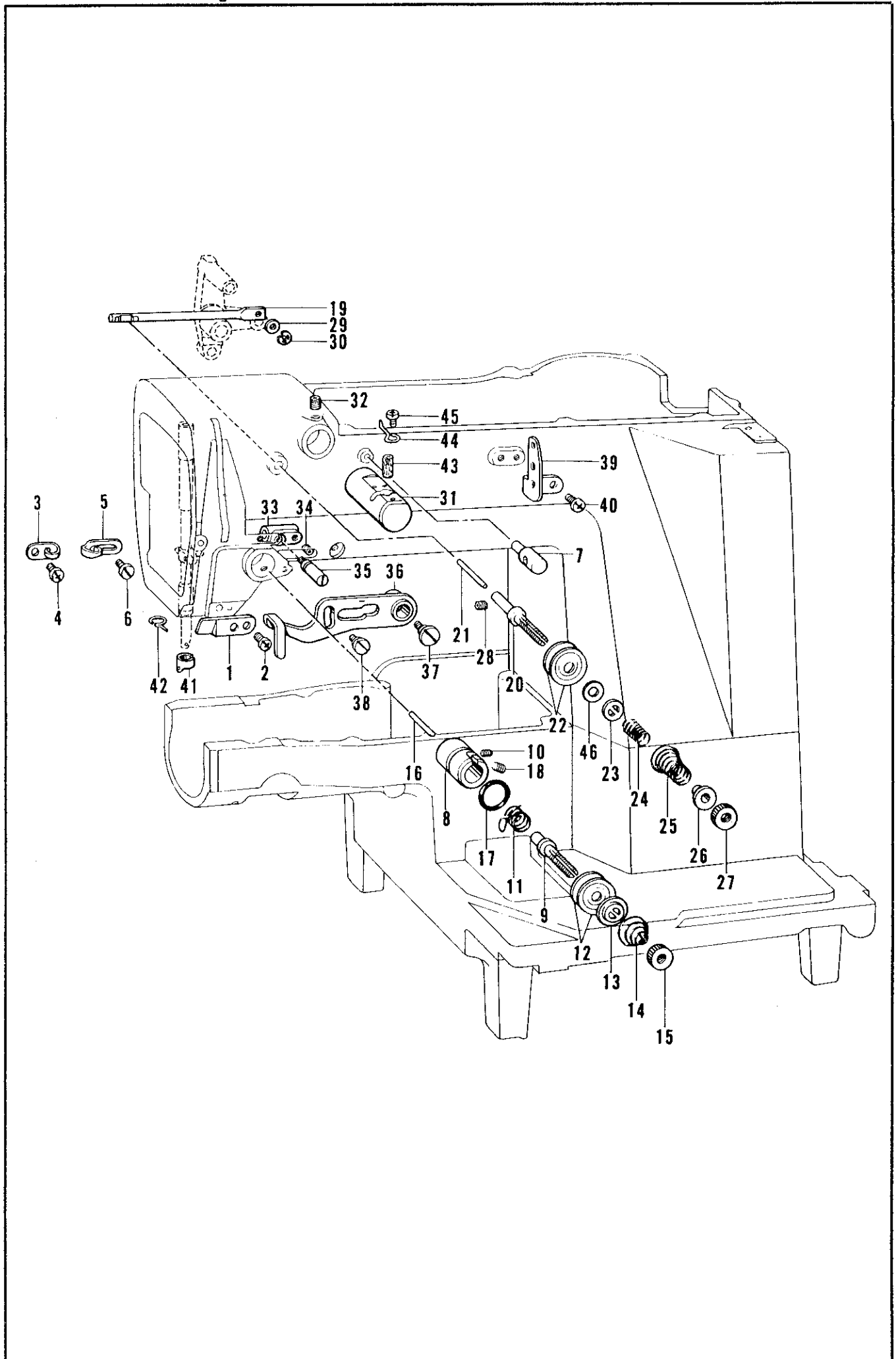

M. 糸通シ関係 / Threading mechanism / FadenführungsVorrichtung /  
Mécánisme de l'enfilage / Mecanismo del enhebrado

REF.NO.	CODE	Q'TY	ヒンメイ	NAME OF PARTS	RMKS
1	152869001	1	アームイトミチ	ARM THREAD GUIDE	
2	062710712	1	ナヘ"コ476-32X7	SCREW 476X7	
3	152870001	1	アームイトカケ	ARM THREAD GUIDE	
4	062670612	1	ナヘ"コ357-40X6	SCREW 357X6	
5	113316001	1	アームイトアンナイ	ARM THREAD GUIDE	
6	112751003	1	シメネジ"3.57	SCREW 3.57	
7	153049001	1	ウワイトアンナイホ"ウ	NEEDLE THREAD GUIDE BAR	
8	152872001	1	イトチヨウシタイ	TENSION BRACKET	
9	100398001	1	イトチヨウシホ"ウ	TENSION STUD	
10	100402004	1	トメネジ"3.57	SET SCREW 3.57	
11	*	1	イトトリハ"ネ	SPRING	
12	145446001	2	イトチヨウシサラ	TENSION DISC	
13	159805001	1	イトチヨウシサラオサエ	TENSION DISC PRESSER	
14	*	1	イトチヨウシハ"ネ	TENSION SPRING	
15	100136001	1	イトチヨウシナツト	TENSION NUT	
16	152873001	1	イトユルメピン	TENSION RELEASE PIN	
17	114294001	1	Oリング"	O RING	
18	103950003	1	トメネジ"5.95	SET SCREW 5.95	
19	152874001	1	フクイトユルメホ"ウ	SUB TENSION RELEASE BAR	
20	152875001	1	フクイトチヨウシホ"ウ	SUB TENSION STUD	
21	152876001	1	フクイトユルメピン	SUB TENSION RELEASE PIN	
22	145446001	2	イトチヨウシサラ	TENSION DISC	
23	152877001	1	イトチヨウシサラオサエ	TENSION DISC WASHER	
24	152878001	1	ウワイトオサエハ"ネ	NEEDLE THREAD SPRING	
25	152879101	1	フクチヨウシハ"ネ	SUB TENSION SPRING	
26	152880001	1	ハ"ネウケ	SPRING HOLDER	
27	100136001	1	イトチヨウシナツト	TENSION NUT	
28	014680422	1	アナトメネジ"4.37クホ"ミ	SET SCREW 4.37	
29	140208001	1	サ"カ"ネ	WASHER	
30	048040342	1	トメワE4	STOP RING E4	
31	152881001	1	エキレイタイクミ	NEEDLE COOLER ASSEMBLY	
32	013760612	1	トメネジ"5.95クホ"ミ	SET SCREW 5.95	
33	152886001	1	イトトリアンナイシ"クウケ	THREAD TAKE-UP GUIDE	
34	014680422	1	アナトメネジ"4.37クホ"ミ	SET SCREW 4.37	
35	152887001	1	イトトリアンナイシ"ク	THREAD TAKE-UP LEVER GUIDE STUD	
36	152888101	1	イトトリレハ"ー	THREAD TAKE-UP LEVER	
37	141528001	1	ダ"ンネジ"6.35	STUD SCREW 6.35	
38	115077003	1	ダ"ンネジ"4.76	STUD SCREW 4.76	
39	152889001	1	ミツメイトカケ	THREAD RETAINER	
40	062670612	2	ナヘ"コ357-40X6	SCREW 357X6	
41	152890001	1	ハリホ"ウワイトアンナイA	NEEDLE BAR THREAD GUIDE (A)	
42	152891001	1	ハリホ"ウメタルDイトアンナイ	NEEDLE BAR BUSH (D) THREAD GUIDE	
43	152883000	1	フェルト8X15.5	FELT 8X15.5	
44	152884001	1	エキレイイトカケ	NEEDLE COOLER THREAD GUIDE	
45	062670412	1	ナヘ"コ357-40X4	SCREW 357X4	
46	153138001	1	サ"カ"ネ	WASHER	

N. 糸巻キ関係/Bobbin winder mechanism/Spuler/  
 Mécanisme de bobineur/Mecanismo del devanador de la canilla

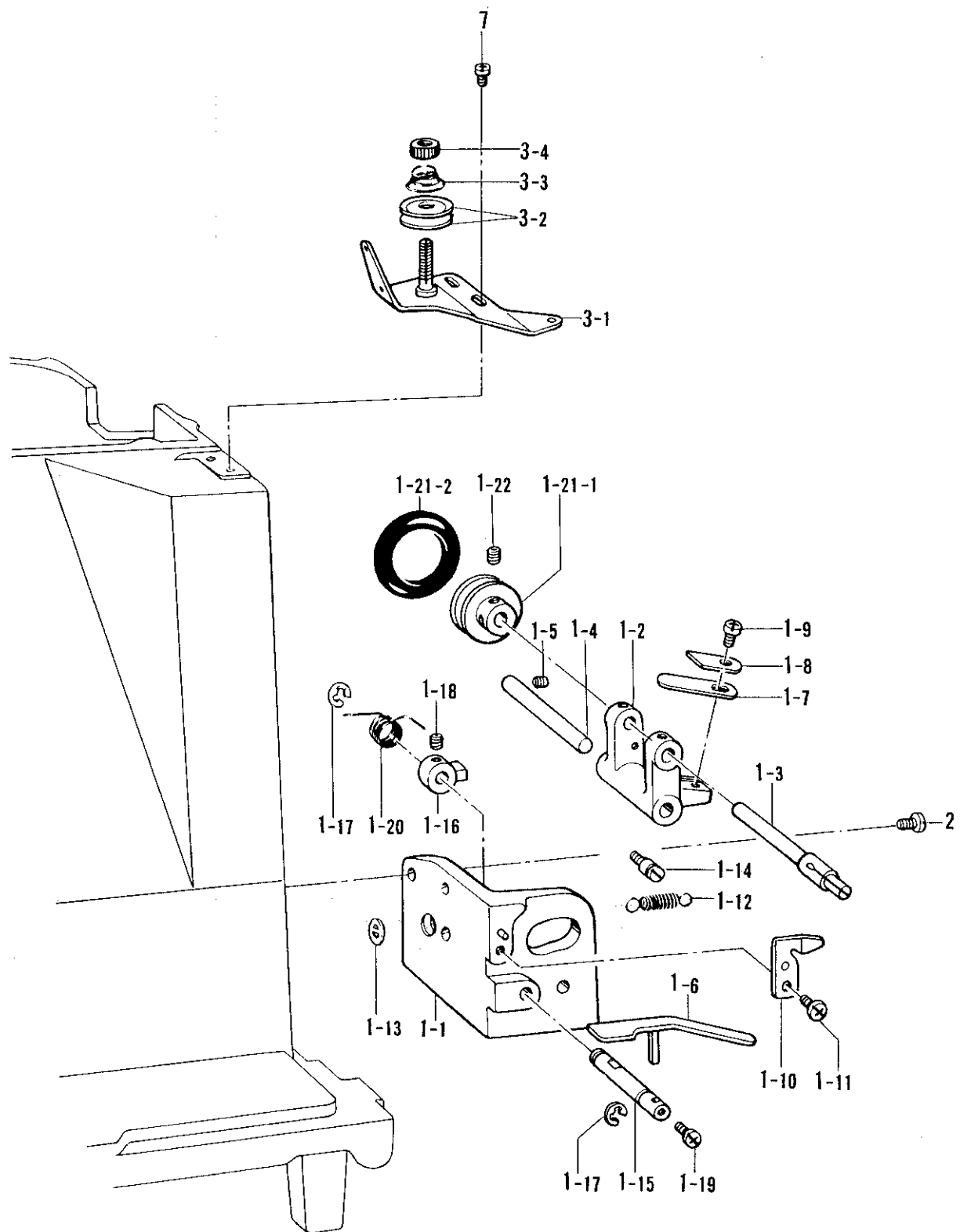

## N. 糸巻キ関係/Bobbin winder mechanism/Spuler/

## Mécanisme de bobineur/Mecanismo del devanador de la canilla

REF.NO.	CODE	Q'TY	ヒンメイ	NAME OF PARTS	RMKS
1	152982109	1	イトマキクミ	BOBBIN WINDER ASSEMBLY	
1-1	152983009	1	イトマキクダイ	BOBBIN WINDER BRACKET	
1-2	152984001	1	イトマキレハ"	BOBBIN WINDER LEVER	
1-3	152933001	1	イトマキシ"ク	BOBBIN WINDER SHAFT	
1-4	152934001	1	イトマキレハ"ーシ"ク	BOBBIN WINDER LEVER SHAFT	
1-5	102716004	1	トメネシ"4.37	SET SCREW 4.37	
1-6	152935001	1	ホ"ヒ"ンオサエ	BOBBIN PRESSER	
1-7	152936001	1	イタハ"ネ	PLATE SPRING	
1-8	152937001	1	サ"カ"ネ	WASHER	
1-9	062670712	1	ナヘ"コ357-40X7	SCREW 357X7	
1-10	152938001	1	メス	KNIFE	
1-11	062680712	1	ナヘ"コ437-40X7	SCREW 437X7	
1-12	152939001	1	イトマキレハ"ーヒキハ"ネ	SPRING	
1-13	115138001	1	レハ"ーヒキハ"ネカケ	SPRING HOOK	
1-14	141550001	1	テイシレハ"ーハ"ネカケ	SPRING HOOK	
1-15	152940001	1	イトマキツメシ"ク	BOBBIN WINDER CLAW STUD	
1-16	142566001	1	イトマキツメ	BOBBIN WINDER CLAW	
1-17	048050342	2	トメワE5	STOP RING E5	
1-18	014680422	2	アナトメネシ"4.37クホ"ミ	SET SCREW 4.37	
1-19	062670712	1	ナヘ"コ357-40X7	SCREW 357X7	
1-20	152941001	1	イトマキツメネシ"リハ"ネ	TWIST SPRING	
1-21-1	154528001	1	イトマキクルマ	BOBBIN WINDER WHEEL	
1-21-2	120448001	1	ゴムワ	RUBBER RING	
1-22	102716004	2	トメネシ"4.37	SET SCREW 4.37	
2	062761412	2	ナヘ"コ595-28X14	SCREW 595X14	
3	S01300009	1	シタイトチヨウシクミ	LOWER THREAD TENSION ASSEMBLY	
3-1	152945001	1	シタイトチヨウシク"イクミ	LOWER THREAD TENSION BRACKET ASSEMBLY	
3-2	145446001	2	イトチヨウシサラ	TENSION DISC	
3-3	104525001	1	イトチヨウシハ"ネ	TENSION SPRING	
3-4	108265009	1	イトチヨウシナツト	TENSION NUT	
7	062680812	2	ナヘ"コ437-40X8	SCREW 437X8	

P. 糸切り関係/Thread trimmer mechanism/Fadenabschneidevorrichtung/  
 Mécanisme de coupe-fil/Mecanismo de la cortadura de hilos

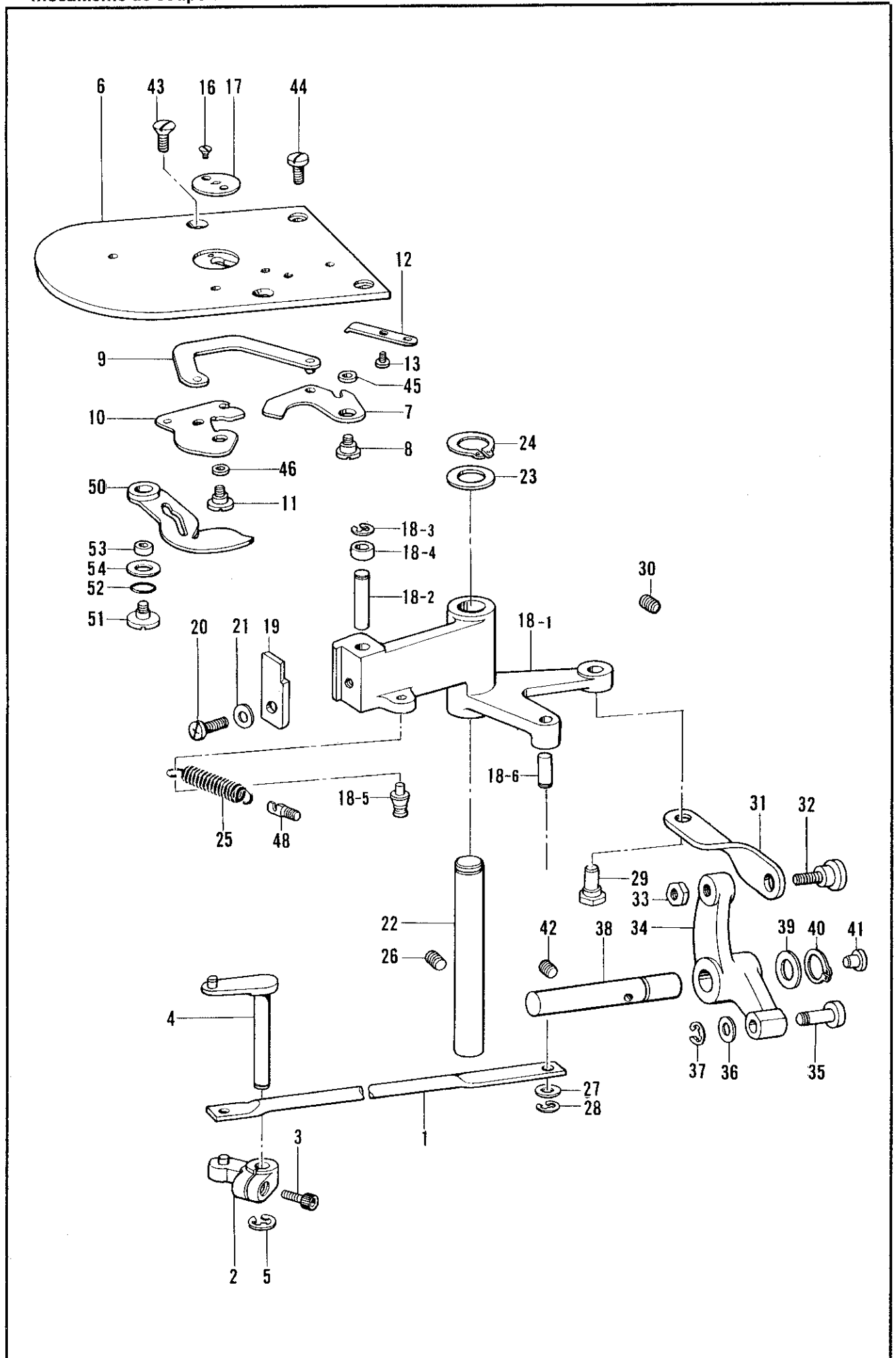



P. 糸切り関係/Thread trimmer mechanism/Fadenabschneidevorrichtung/  
Mécánisme de coupe-fil/Mecanismo de la cortadura de hilos

REF.NO.	CODE	Q'TY	ヒンメイ	NAME OF PARTS	RMKS
1	152892001	1	イトキリレンケツロツト	THREAD TRIMMER CONNECTING ROD	
2	152896001	1	イトキリウテ"AKミ	THREAD TRIMMER ARM ASSEMBLY (A)	
3	018681022	1	アナホ"ルト4.37X10	BOLT 4.37X10	
4	152893101	1	イトキリウテ"B	THREAD TRIMMER ARM (B)	
5	048050342	1	トメフE5	STOP RING E5	
6	152995001	1	ハリイタS	NEEDLE PLATE (S)	
7	152981001	1	イトキリウテ"C	KNIFE ARM (C)	
8	153222001	1	シメネジ"4.37	SCREW 4.37	
9	152897201	1	イトキリレンカンクミ	THREAD TRIMMER CONNECTING ROD ASSEMBLY	
10	152901001	1	イト"ウハクミ	MOVABLE KNIFE ASSEMBLY	
11	152904001	1	シメネジ"4.37	SCREW 4.37	
12	152905001	1	コテイハ	FIXED KNIFE	
13	111140002	2	シメネジ"2.38	SCREW 2.38	
16	100360003	2	サラネジ"2.38	SCREW 2.38	
17	*	1	ハリアナイタ	NEEDLE HOLE PLATE	
18-1	152912001	1	イトキリカムレハ"ー	THREAD TRIMMER CAM LEVER	
18-2	152913001	1	コロシ"ク	ROLLER SHAFT	
18-3	048040342	1	トメフE4	STOP RING E4	
18-4	152914001	1	コロ	ROLLER	
18-5	154789001	1	ハ"ネカケ	SPRING HOOK	
18-6	152919001	1	イトキリロツト"ヒ"ン	THREAD TRIMMER ROD PIN	
19	152915001	1	イトキリカムレハ"ーツメ	THREAD TRIMMER CAM LEVER CLAW	
20	062761412	1	ナヘ"コ595-28X14	SCREW 595X14	
21	025060132	1	ヒラサ"ガ"ネシヨウ6	PLAIN WASHER 6	
22	152916001	1	イトキリカムレハ"ーシ"ク	THREAD TRIMMER CAM LEVER SHAFT	
23	152917001	1	サ"ガ"ネ	WASHER	
24	048120142	1	トメフシ"クヨウC12	STOP RING C12	
25	154788001	1	イトキリカムレハ"ーハ"ネ	SPRING	
26	014760622	1	アナトメネジ"5.95	SET SCREW 5.95	
27	140208001	1	サ"ガ"ネ	WASHER	
28	048040342	1	トメフE4	STOP RING E4	
29	152920001	1	イトキリリンクチヨウセツシ"ク	STUD	
30	014760622	1	アナトメネジ"5.95	SET SCREW 5.95	
31	152921001	1	イトキリリンク	THREAD TRIMMER LINK	
32	151907001	1	ダ"ンネジ"5.95	STUD SCREW 5.95	
33	150553001	1	ナツト5.95	NUT 5.95	
34	152922001	1	イトキリサト"ーレハ"ー	THREAD TRIMMER LEVER	
35	152923001	1	イトキリサト"ーレハ"ーコロ	THREAD TRIMMER ROLLER	
36	112468001	1	サ"ガ"ネ	WASHER	
37	048050342	1	トメフE5	STOP RING E5	
38	153482001	1	イトキリサト"ーレハ"ーシ"ク	DRIVING SHAFT	
39	142628001	1	スイハイオクリクランクリン"グ	FEED ROCK CRANK RING	
40	048110142	1	トメフシ"クヨウC11	STOP RING C11	
41	111865009	1	オイルメクラセン	OIL CAP	
42	014760622	1	アナトメネジ"5.95	SET SCREW 5.95	
43	100032004	2	サラネジ"4.37	SCREW 4.37	
44	153208002	2	シメネジ"4.37	SCREW 4.37	
45	153220001	1	イトキリウテ"Cカラー	KNIFE ARM (C) COLLAR	
46	153219001	1	イト"ウハカラー	MOVABLE KNIFE COLLAR	
48	141334001	1	ハ"ネカケ	SPRING HOOK	
50	152906101	1	シタイトサハ"キA	LOWER THREAD RETAINER (A)	
51	153598001	1	シメネジ"4.37	SCREW 4.37	
52	081008070	1	Oリング"P8	O RING P8	
53	153597001	1	シタイトサハ"キカラー	LOWER THREAD RETAINER COLLAR	
54	153596001	1	サ"ガ"ネ	WASHER	

Q. 糸払イ関係 / Thread wiper mechanism / Fadenwischvorrichtung /  
 Mécanisme de tire-fil / Mecanismo del limpiador de hilo

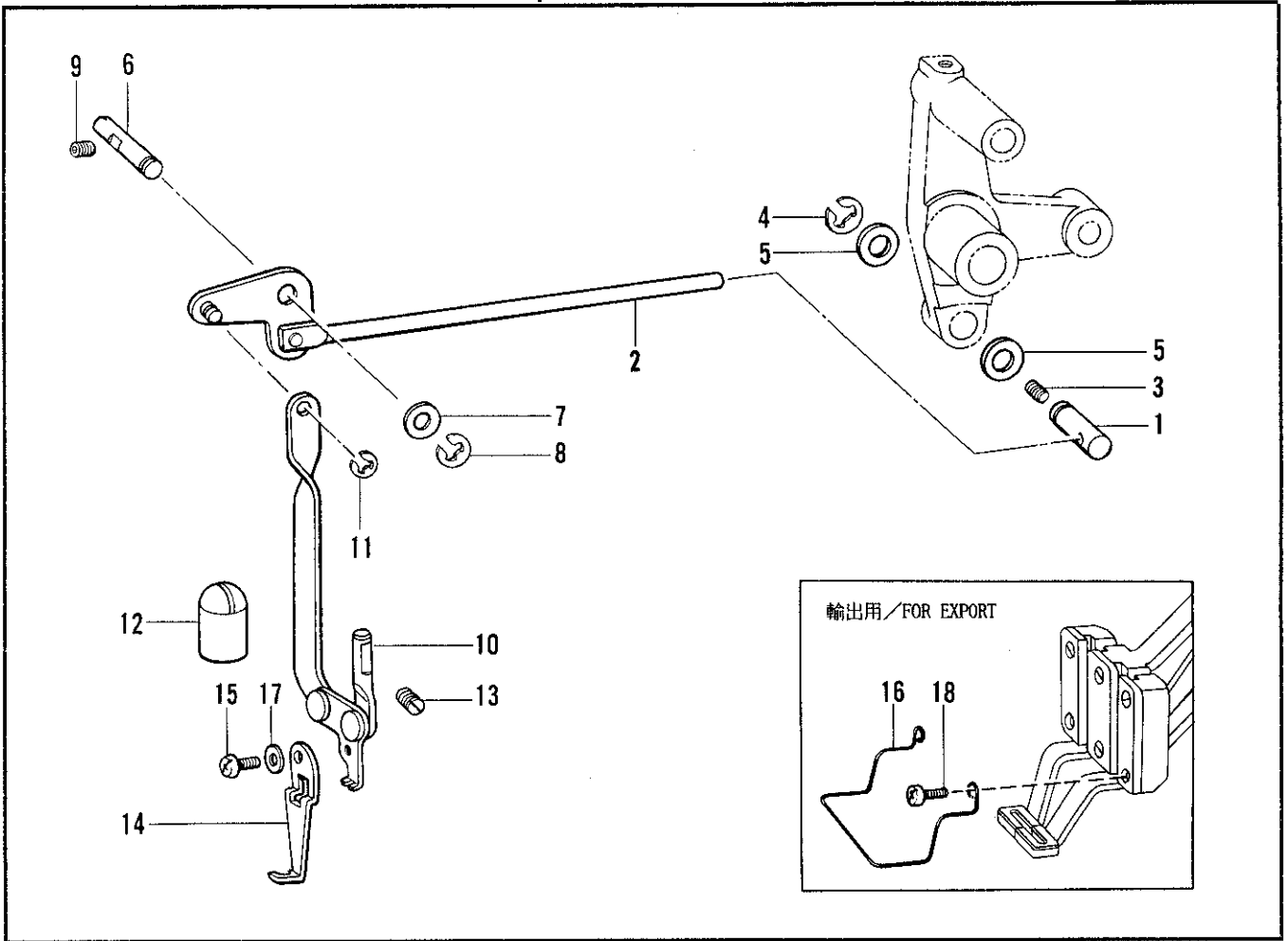

R. 糸締メ関係 / Thread nipper mechanism / Fadenspannvorrichtung /  
 Mécanisme de pince-fil / Mecanismo de la mordaza para hilo

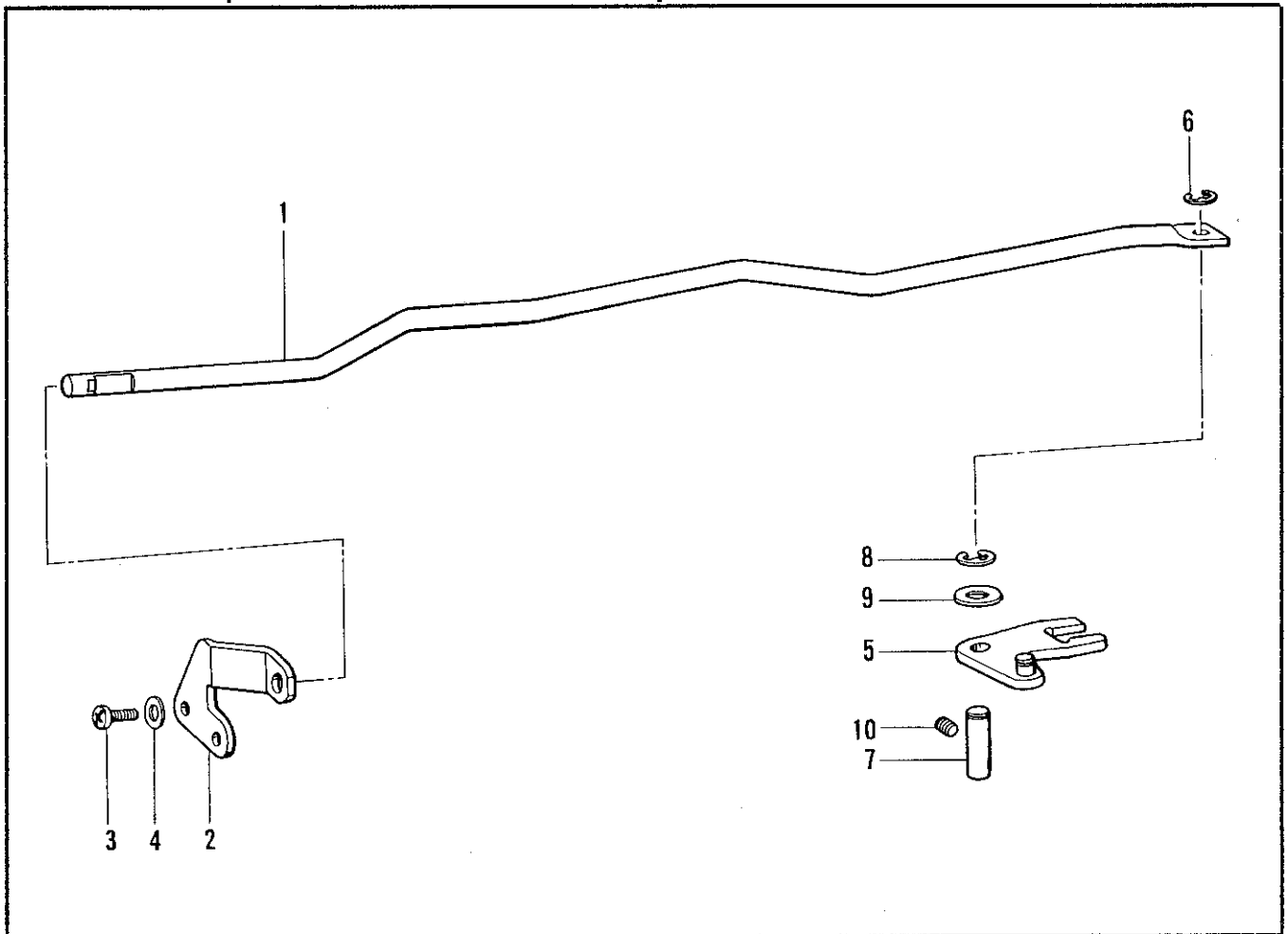

Q. 糸払い関係 / Thread wiper mechanism / Fadenwischvorrichtung /  
Mécánisme de tire-fil / Mecanismo del limpiador de hilo

REF.NO.	CODE	Q'TY	ヒンメイ	NAME OF PARTS	RMKS
1	152815001	1	ワイパーロツト"ジ"ク	THREAD WIPER ROD SHAFT	
2	152816001	1	ワイパーロツト"クミ	THREAD WIPER ROD ASSEMBLY	
3	014680622	1	アナトメネジ"4.37クホ"ミ	SET SCREW 4.37	
4	048060342	1	トメワE6	STOP RING E6	
5	116629001	2	サ"ガ"ネ	WASHER	
6	152822001	1	ワイパー"ジ"ク	THREAD WIPER SHAFT	
7	025770232	1	ヒラサ"ガ"ネチユウ6.35	PLAIN WASHER 6.35	
8	048040342	1	トメワE4	STOP RING E4	
9	014680622	1	アナトメネジ"4.37クホ"ミ	SET SCREW 4.37	
10	152823001	1	ワイパーウデ"クミ	THREAD WIPER ARM ASSEMBLY	
11	048030342	1	トメワE3	STOP RING E3	
12	152827009	1	オイルキリセン	OIL CAP	
13	013710712	1	トメネジ"4.76クホ"ミ	SET SCREW 4.76	
14	156206001	1	ワイパー-A	THREAD WIPER (A)	
15	062670512	1	ナヘ"コ357-40X5	SCREW 357X5	
16	156495001	1	-----	FINGER GUARD	
17	025350132	1	ヒラサ"ガ"ネシヨウ	PLAIN WASHER	
18	062671012	2	-----	SCREW 357X10	

R. 糸締メ関係 / Thread nipper mechanism / Fadenspannvorrichtung /  
Mécánisme de pince-fil / Mecanismo de la mordaza para hilo

REF.NO.	CODE	Q'TY	ヒンメイ	NAME OF PARTS	RMKS
1	152925101	1	ウワイトユルメホ"ウ	NEEDLE THREAD RELEASE SHAFT	
2	152926001	1	ユルメホ"ウササイイタ	TENSION RELEASE BAR PLATE	
3	062671012	2	ナヘ"コ357-40X10	SCREW 357X10	
4	025350332	2	ヒラサ"ガ"ネタ"イ3.5	PLAIN WASHER 3.5	
5	152988001	1	ウワイトユルメレハ"ークミ	NEEDLE THREAD RELEASE LEVER ASSEMBLY	
6	048040342	1	トメワE4	STOP RING E4	
7	152929001	1	ウワイトユルメレハ"ー"ジ"ク	NEEDLE THREAD RELEASE LEVER SHAFT	
8	048050342	1	トメワE5	STOP RING E5	
9	025770232	1	ヒラサ"ガ"ネチユウ6.35	PLAIN WASHER 6.35	
10	014760622	1	アナトメネジ"5.95	SET SCREW 5.95	

S. 付属装置セット/Attachment set/Anbausatz/Jeu d'accessoires/Juego de fijación

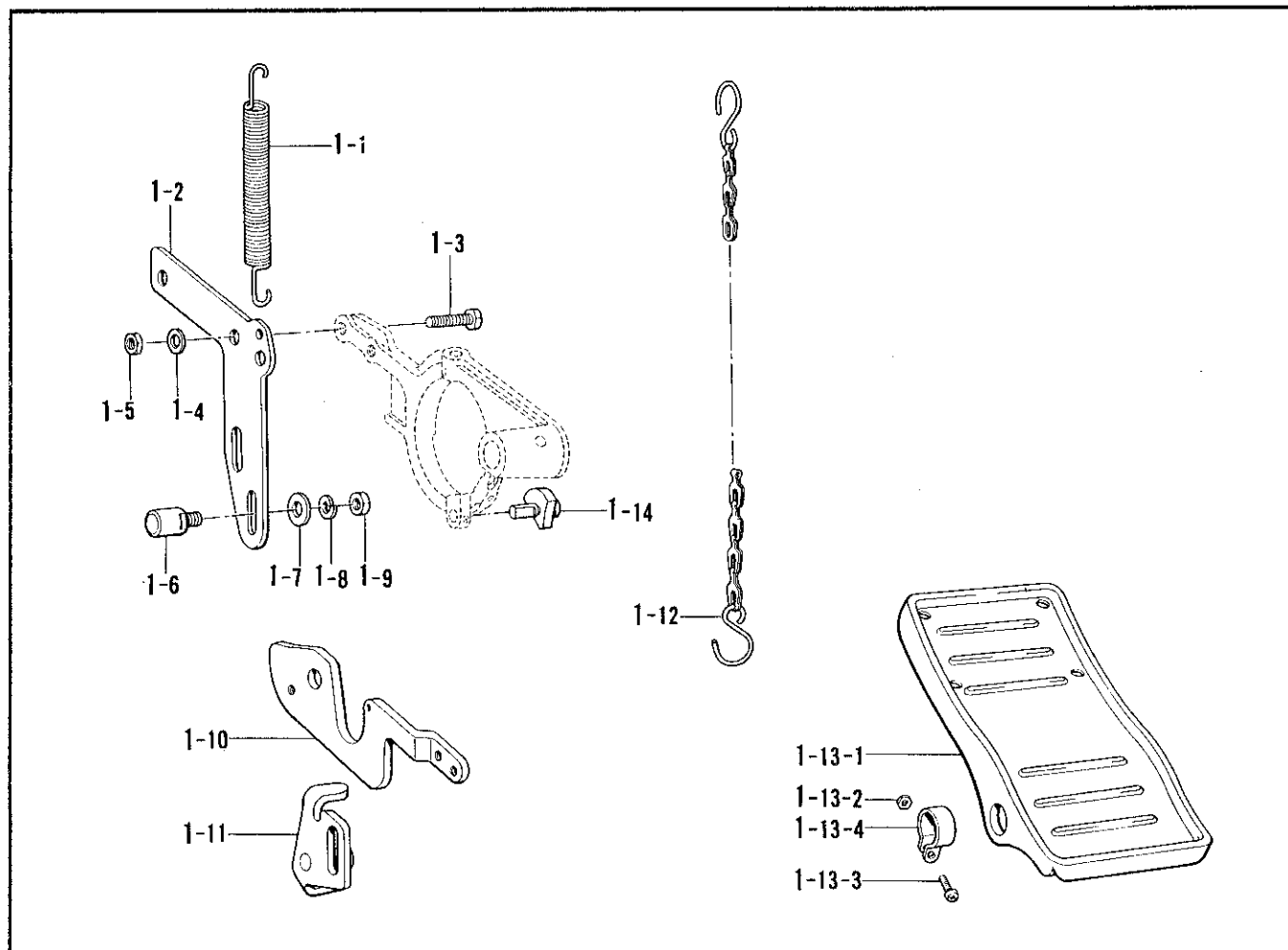

T. 特別注文部品/Option Parts/Sonderzubehör/Pièces en option/Piezas opcionales

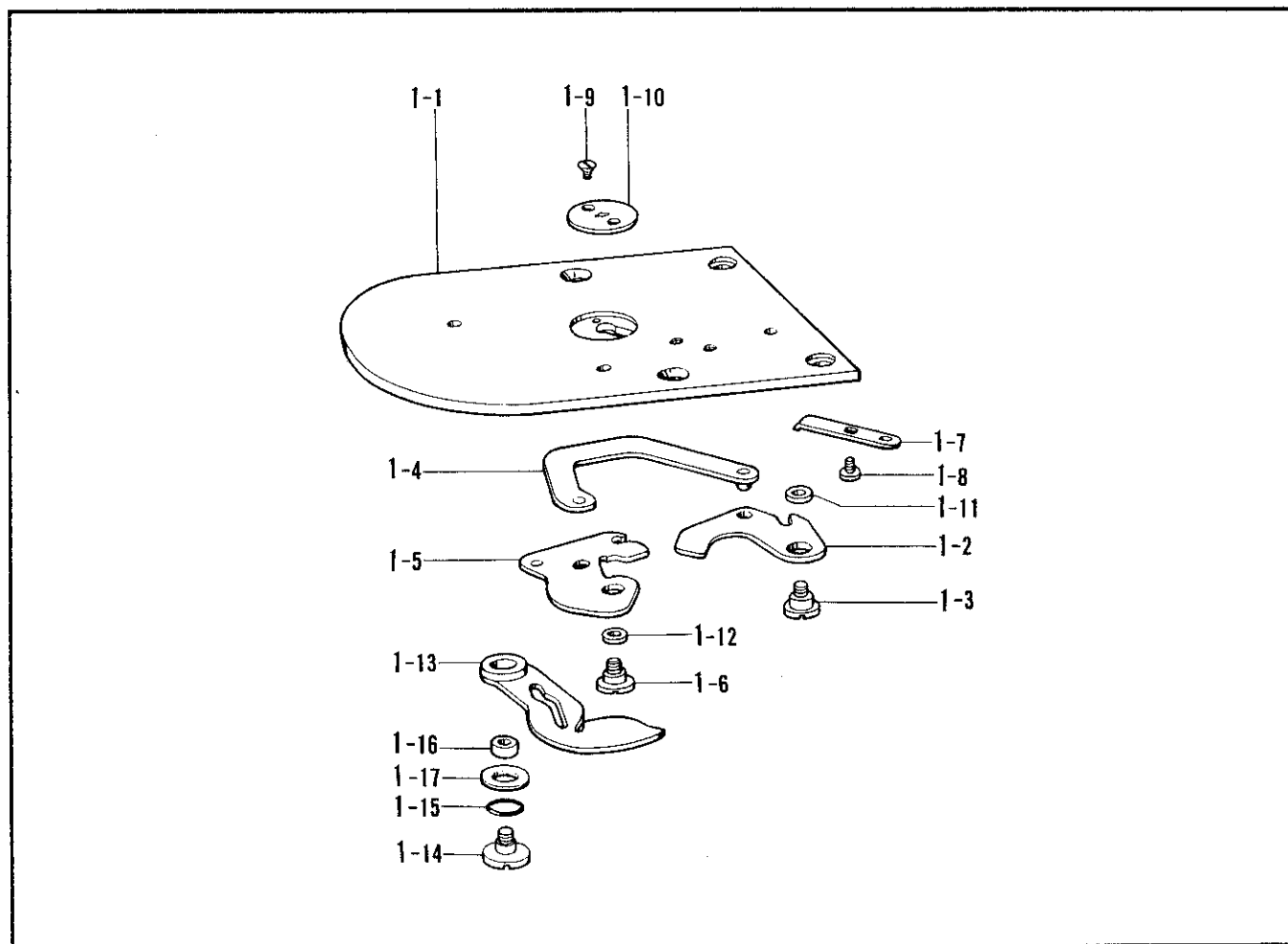

S. 付属装置セット/Attachment set/Anbausatz/Jeu d'accessoires/Juego de fijación

REF.NO.	CODE	Q'TY	ヒンメイ	NAME OF PARTS	RMKS
1	154709002	1	メカ2ペダルソウチクミ	MECHANISM TWO PEDALS ASSEMBLY	
1-1	154452001	1	クツ"ウレハ"ーイタヒキハ"ネ	SPRING	
1-2	154448001	1	クツ"ウレハ"ーイタ	DRIVE LEVER PLATE	
1-3	017762012	2	ボルト5.95X20	BOLT 5.95X20	
1-4	025060232	2	ヒラサ"カ"ネチユウ6	PLAIN WASHER 6	
1-5	150553001	2	ナツト5.95	NUT 5.95	
1-6	154449001	2	ストツハ"ー	STOPPER	
1-7	025080232	2	ヒラサ"カ"ネチユウ8	PLAIN WASHER 8	
1-8	028080242	2	ハ"ネサ"カ"ネ2-8	SPRING WASHER 2-8	
1-9	105812003	2	ナツト7.94	NUT 7.94	
1-10	154450001	1	Pサト"ウレハ"ーB	RELEASE DRIVE LEVER B	
1-11	154451001	1	キト"ウストツハ"ーB	DRIVE STOPPER (B)	
1-12	149247001	1	クサリクミ	CHAIN ASSEMBLY	
1-13	116185209	1	ペ"タルクミ	PEDAL ASSEMBLY	
1-13-1	117437109	1	オサエアケ"フミイタ	FOOT PEDAL	
1-13-2	021400106	2	1シユナツト4	NUT 4	
1-13-3	062401416	2	ナヘ"コ4X14	SCREW 4X14	
1-13-4	116016001	2	ペ"タルトメ	PEDAL STOPPER	
1-14	154681001	1	オサエアケ"コロシ"ククミB	ROLLER SHAFT ASSEMBLY (B)	

T. 特別注文部品/Option Parts/Sonderzubehör/Pièces en option/Piezas opcionales

REF.NO.	CODE	Q'TY	ヒンメイ	NAME OF PARTS	RMKS
1	S18426001	1	ハリイタSクミ	NEEDLE PLATE (S) ASSEMBLY	
1-1	152995001	1	ハリイタS	NEEDLE PLATE (S)	
1-2	152981001	1	イトキリウデ"C	KNIFE ARM (C)	
1-3	153222001	1	シメネジ"4.37	SCREW 4.37	
1-4	152897201	1	イトキリルンカンクミ	KNIFE CONNECTING ROD ASSEMBLY	
1-5	152901001	1	イト"ウハクミ	MOVABLE KNIFE ASSEMBLY	
1-6	152904001	1	シメネジ"4.37	SCREW 4.37	
1-7	152905001	1	コテイハ	FIXED KNIFE	
1-8	111140002	2	シメネジ"2.38	SCREW 2.38	
1-9	100360003	2	サラネジ"2.38	SCREW 2.38	
1-10	156150001	1	ハリアナイタB	NEEDLE PLATE (B)	
1-11	153220001	1	イトキリウデ"Cカラー	KNIFE ARM (C) COLLAR	
1-12	153219001	1	イト"ウハカラー	MOVABLE KNIFE COLLAR	
1-13	152906101	1	シタイトサハ"キA	BOBBIN THREAD RETAINER (A)	
1-14	153598001	1	シメネジ"4.37	SCREW 4.37	
1-15	081008070	1	Oリング"P8	O RING P8	
1-16	153597001	1	シタイトサハ"キカラー	BOBBIN THREAD RETAINER COLLAR	
1-17	153596001	1	サ"カ"ネ	WASHER	

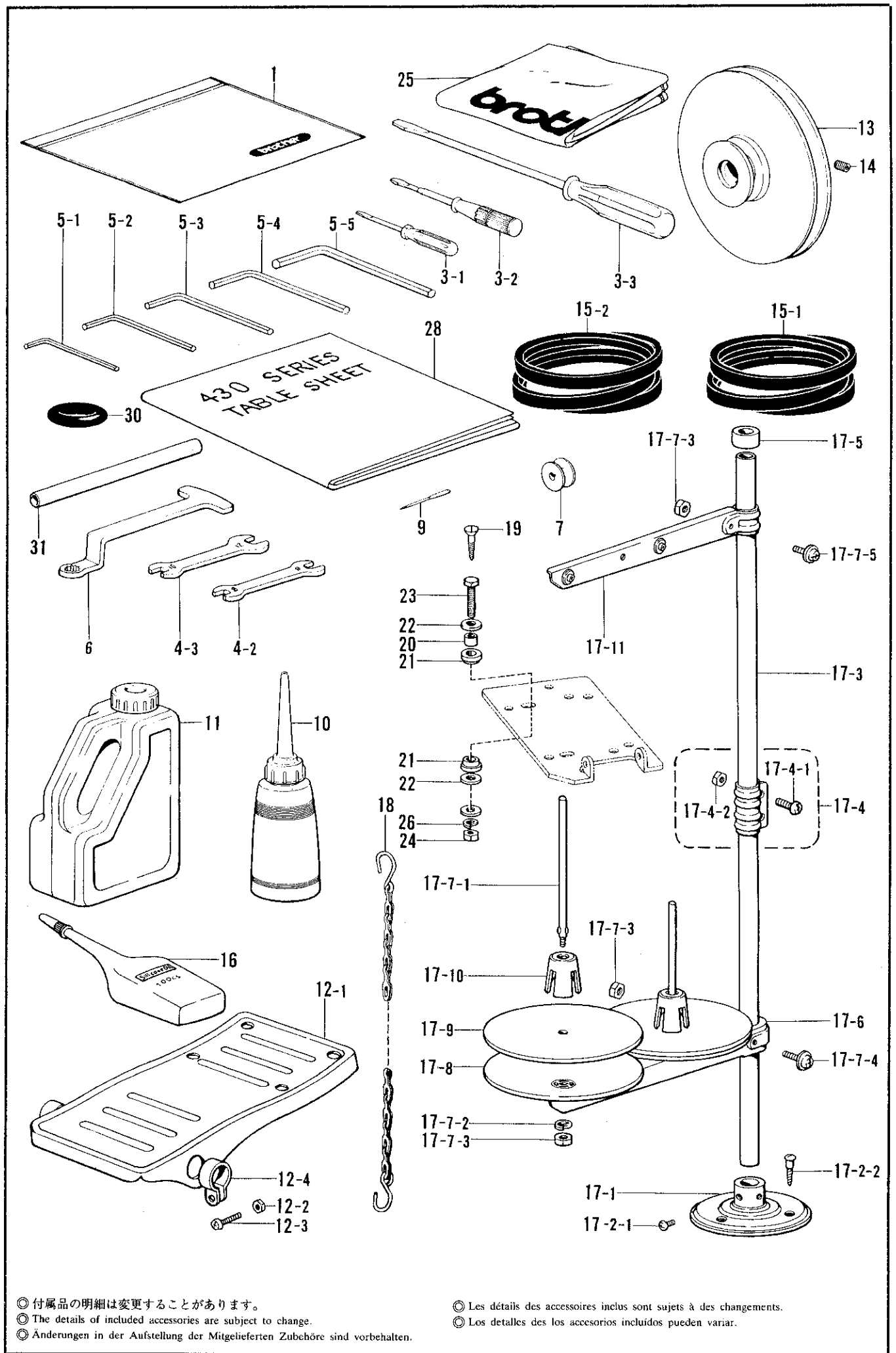

◎ 付属品の明細は変更することがあります。  
 ◎ The details of included accessories are subject to change.  
 ◎ Änderungen in der Aufstellung der Mitgelieferten Zubehöre sind vorbehalten.

◎ Les détails des accessoires inclus sont sujets à des changements.  
 ◎ Los detalles de los accesorios incluidos pueden variar.

## Z. 付属品関係/Accessories/Zubehör/Accessoires/Accessorios

REF.NO.	CODE	Q'TY	ヒンメイ	NAME OF PARTS	RMKS
1	122991001	1	フゾクヒンホリフクロ	ACCESSORY BAG	
3-1	142443001	1	ネジ"マウシ1.9X52	SCREW DRIVER 1.9X52	
3-2	118837001	1	ネジ"マウシ3.4X70	SCREW DRIVER 3.4X70	
3-3	101572101	1	ネジ"マウシ5.5X190	SCREW DRIVER 5.5X190	
4-2	100887001	1	スパナ8X9	SPANNER 8X9	
4-3	107780001	1	スパナ10X12	SPANNER 10X12	
5-1	142002001	1	6カクホ"ウスハナ2	HEXAGONAL WRENCH 2	
5-2	142721001	1	6カクホ"ウスハナ3	HEXAGONAL WRENCH 3	
5-3	118064001	1	6カクホ"ウスハナ4	HEXAGONAL WRENCH 4	
5-4	150335001	1	6カクホ"ウスハナ5	HEXAGONAL WRENCH 5	
5-5	115157001	1	6カクホ"ウスハナ6	HEXAGONAL WRENCH 6	
6	152765001	1	メカ"ネレンチ10	WRENCH 10	
7	159613001	3	ホ"ビツン	BOBBIN	
9	*	4	ミシンハリDP	NEEDLE DP	
10	114483002	1	ホ"リオイルークミ	OILER ASSEMBLY	
11	154702001	1	オイルタンク	OIL TANK	
12	116185209	1	ペタルクミ	PEDAL ASSEMBLY	
12-1	117437109	1	オサエアケ"フミイタ	FOOT PEDAL	
12-2	021400106	2	1シユナツト4	NUT 4	
12-3	062401416	2	ナヘ"コ4X14	SCREW 4X14	
12-4	116016001	2	ペタルトメ	PEDAL STOPPER	
13	*	1	モータプーリ	MOTOR PULLEY	
14	014760622	2	アナトメネジ"5.95	SET SCREW 5.95	
15-1	082104891	1	V"ベルトM48	V-BELT M48	
15-2	*	1	V"ベルトM	V-BELT M	
16	*	1	シリコンオイル	SILICON OIL	
17	S02761009	1	イトタテダ"イ	COTTON STAND	
17-1	150189009	1	ブラケット	COTTON STAND BASE	
17-2	S02773001	1	ブラケットネジ"セット	COTTON STAND BASE SCREW SET	
17-2-1	062060806	2	ナヘ"コ6X8	SCREW 6X8	
17-2-2	031452206	3	マルモク45X22	SCREW 45X22	
17-3	150172003	2	コラムパイプ"	COLUMN PIPE	
17-4	150106003	1	コラムジ"ョイントクミ	COLUMN JOINT ASSEMBLY	
17-4-1	062501406	2	ナヘ"コ5X14	SCREW 5X14	
17-4-2	021500106	2	1シユナツト5	NUT 5	
17-5	150174000	1	コラムキャツプ"	COLUMN CAP	
17-6	S02778002	1	スプールホルダ"ー2	SPOOL HOLDER 2	
17-7	S02780001	1	スプールネジ"セット2	SPOOL SCREW SET 2	
17-7-1	150179002	2	スプールシ"クB	SPOOL SHAFT (B)	
17-7-2	028050246	2	ハ"ネサ"カ"ネ2-5	SPRING WASHER 2-5	
17-7-3	021500106	4	1シユナツト5	NUT 5	
17-7-4	050503006	1	ナヘ"コヒラサ"5X30	SCREW 5X30	
17-7-5	050501406	1	ナヘ"コヒラサ"5X14	SCREW 5X14	
17-8	150180001	2	ウケサ"ラ	SPOOL STAND BASE	
17-9	150182000	2	スプールマット	SPOOL MAT	
17-10	126863001	2	スプールクツシヨ"ン	SPOOL CUSHION	
17-11	S02786002	1	スレツト"ハンガ"ークミ2	THREAD HANGER ASSEMBLY 2	
18	149247001	1	クサリクミ	CHAIN ASSEMBLY	
19	106030001	4	サラモクネジ"6.2X32	SCREW 6.2X32	
20	152863001	4	クツシヨ"ンカラー	CUSHION COLLAR	
21	152864000	8	クツシヨ"ン	CUSHION	
22	025800332	12	ヒラサ"カ"ネダ"イ7.14	PLAIN WASHER 7.14	
23	017062503	4	6カクホ"ルト6X25	BOLT 6X25	
24	021060102	4	ナツト1シユ6	NUT 6	
25	144226001	1	-----	HEAD COVER	
26	028060242	4	ハ"ネサ"カ"ネ2-6	SPRING WASHER 2-6	
28	153574201	1	テーブ"ルシート	TABLE SHEET	
30	120448001	1	ゴ"ムワ	RUBBER RING	
31	154760001	1	ホ"ウスハナパイプ"	PIPE	

仕様別部品一覧表/DIFFERENT PARTS LIST/ZUBEHÖRLISTE/  
LISTE DES PIÈCES ACCESSOIRES/LISTA DE PIEZAS ACCESORIAS

SUB CLASS	サンショウ ハンゴウ REF.NO.	A-62	C-27	F-35	F-35-8	F-35-9	F-35-18	F-44
	ヒンメイ PARTS	ショウラヘル	ミシンハリDP	オサイウテクミ	オサイアシR	オサイアシL	オサイハネ	オクリイタ
	ショウ SPEC	LABEL	NEEDLE DP	PRESSER ARM ASSEMBLY	WORK CLAMP (R)	WORK CLAMP (L)	SPRING	FEED PLATE
-1	イッパンヒフクヨウ ORDINARY CLOTHES	153056201	107415016 (DPX5#16)	152767009	152777001	152778001	153568001 (A)	153055201
-2	デニムヨウ DENIM	153056202	145646019 (DPX17#19)	154526009	153608101	154527001	154356001 (C)	153610101
-3	デニムヨウ DENIM	153056203	↑	↑	↑	↑	↑	↑
-4	イッパンヒフクヨウ ORDINARY CLOTHES	153056204	107415016 (DPX5#16)	152767009	152777001	152778001	153568001 (A)	153055201
-5	イッパンヒフクヨウ ORDINARY CLOTHES	153056205	↑	153033009	152779001	152780001	↑	153207201
-6	デニムヨウ DENIM	153056206	145646019 (DPX17#19)	154526009	153608101	154527001	154356001 (C)	153610101
-7	メリヤスヨウ KNITTED MATERIALS	153056207	107415009 (DPX5#9)	153033009	152779001	152780001	153568001 (A)	152791201
-8	イッパンヒフクヨウ ORDINARY CLOTHES	153056208	107415016 (DPX5#16)	↑	↑	↑	↑	153207201
-9	メリヤスヨウ KNITTED MATERIALS	153056209	107415009 (DPX5#9)	↑	↑	↑	↑	152791201



SUB CLASS	ザンショウ ハンゴウ REF.NO.	H-15	H-16	H-22	J-10	J-10-1	K-26	K-31
	ヒンメイ PARTS ショウ SPEC	チェンシ"キ"ヤW CHANGE GEAR (W)	チェンシ"キ"ヤC CHANGE GEAR (C)	オクリカム FEED CAM	パワーカムセット POWER CAM SET	パワーカムクミ POWER CAM ASSEMBLY	オオカム LARGE SHUTTLE HOOK	ナカカム INNER ROTARY HOOK
-1	イッパンヒフクヨウ ORDINARY CLOTHES	152721000 (42)	152722000 (42)	152727001 (42S)	155523001	151933001	152682001 (A)	152685101 (A)
-2	デニムヨウ DENIM	↑	↑	153053001 (42D)	S13165001 (B)	S13166001 (B)	152686001 (B)	152687001 (B)
-3	デニムヨウ DENIM	153312000 (35)	153313000 (35)	153314001 (35D)	↑	↑	↑	↑
-4	イッパンヒフクヨウ ORDINARY CLOTHES	152719000 (28)	152720000 (28)	153054001 (28S)	155523001	151933001	152682001 (A)	152685101 (A)
-5	イッパンヒフクヨウ ORDINARY CLOTHES	↑	↑	153343001 (28K)	↑	↑	↑	↑
-6	デニムヨウ DENIM	↑	↑	153321001 (28D)	S13165001 (B)	S13166001	152686001 (B)	152687001 (B)
-7	メリヤスヨウ KNITTED MATERIALS	↑	↑	152726001 (28M)	155523001	151933001	152682001 (A)	152685101 (A)
-8	イッパンヒフクヨウ ORDINARY CLOTHES	152721000 (42)	152722000 (42)	153344001 (21K)	↑	↑	↑	↑
-9	メリヤスヨウ KNITTED MATERIALS	↑	↑	153315001 (21M)	↑	↑	↑	↑

SUB CLASS	サンショウ パンゴウ REF.NO.	M-11	M-14	P-17	Z-9	Z-13	Z-13	Z-15-2
	ヒンメイ PARTS	イトリハ"ネ SPRING	イトチョウシハ"ネ TENSION SPRING	ハリアナイタ NEEDLE HOLE PLATE	ミシンハリDP NEEDLE DP	モータプーリ MOTOR PULLEY 50HZ	モータプーリ MOTOR PULLEY 60HZ	Vベルト V BELT 50HZ
	ショウ SPEC							
-1	イッパンヒフクヨウ ORDINARY CLOTHES	145519001	104525001	156150001 (B)	107415016 (DPX5#16)			
-2	デニムヨウ DENIM	144588001 (B)	107606001	156151001 (C)	145646019 (DPX17#19)			
-3	デニムヨウ DENIM	↑	↑	↑	↑	(コクナイヨウ) (FOR DOMESTIC) 153109001	(コクナイヨウ) (FOR DOMESTIC) 153108001	(コクナイヨウ) (FOR DOMESTIC) 082105190 (M51)
-4	イッパンヒフクヨウ ORDINARY CLOTHES	145519001	104525001	156150001 (B)	107415016 (DPX17#19)			
-5	イッパンヒフクヨウ ORDINARY CLOTHES	↑	↑	↑	↑			
-6	デニムヨウ DENIM	144588001 (B)	107606001	156151001 (C)	145646019 (DPX17#19)	(コクニツヨウ) (FOR EXPORT) 154540001	(コクニツヨウ) (FOR EXPORT) 154541001	(コクニツヨウ) (FOR EXPORT) 082105290
-7	メリヤスヨウ KNITTED MATERIALS	145519001	104525001	156149001 (A)	107415009 (DPX5#9)	(φ14) 154542001 (φ15.88)	(φ14) 154543001 (φ15.88)	(M52)
-8	イッパンヒフクヨウ ORDINARY CLOTHES	↑	↑	156150001 (B)	107415016 (DPX5#16)			
-9	メリヤスヨウ KNITTED MATERIALS	↑	↑	156149001 (A)	107415009 (DPX5#9)			

SUB CLASS	サンショウ パンゴウ REF.NO.	Z-15-2	Z-16					
	ヒンメイ PARTS シヨウ SPEC	Vベルト V BELT 60HZ	シリコンオイル SILICON OIL					
-1	イッパンヒフクヨウ ORDINARY CLOTHES	(コクナイヨウ) (FOR DOMESTIC) 082105090 (M50)	S06706001					
-2	デニムヨウ DENIM		-----					
-3	デニムヨウ DENIM		-----					
-4	イッパンヒフクヨウ ORDINARY CLOTHES		S06706001					
-5	イッパンヒフクヨウ ORDINARY CLOTHES		↑					
-6	デニムヨウ DENIM		(エシユツヨウ) (FOR EXPORT) 082105190	-----				
-7	メリヤスヨウ KNITTED MATERIALS		(M51)	-----				
-8	イッパンヒフクヨウ ORDINARY CLOTHES		S06706001					
-9	メリヤスヨウ KNITTED MATERIALS		-----					

オサエアシ LPL  
WORK CLAMP LPL  
153202001

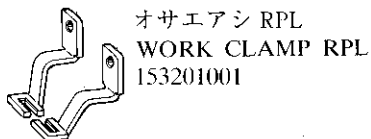
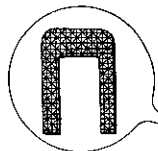

オサエアシ RPL  
WORK CLAMP RPL  
153201001

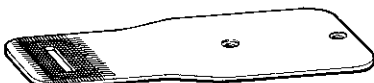
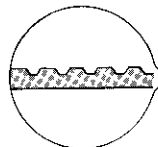

オクリイタ PL  
FEED PLATE PL  
153205201

オサエアシ LPS  
WORK CLAMP LPS  
153204001

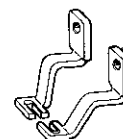
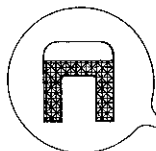

オサエアシ RPS  
WORK CLAMP RPS  
153203001

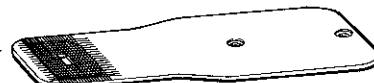
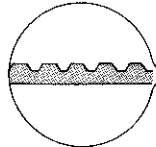

オクリイタ PS  
FEED PLATE PS  
153206201

オサエアシ L デニム  
WORK CLAMP L DENIM  
152782001

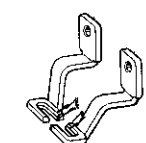
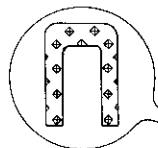

オサエアシ R デニム  
WORK CLAMP R DENIM  
152781001

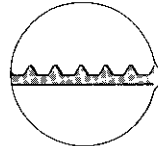

オクリイタ デニム  
FEED PLATE DENIM  
152792001

オサエアシ L 1 インチ  
WORK CLAMP L 1 INCH  
S00907001

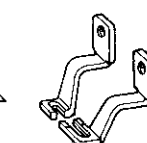
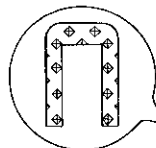

オサエアシ R 1 インチ  
WORK CLAMP R 1 INCH  
S00906001

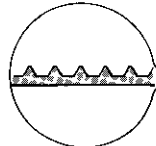

オクリイタ 1 インチ  
FEED PLATE 1 INCH  
S00908001



ハリアナイト G  
NEEDLE HOLE PLATE G  
(φ2.5)  
156155001



ハリアナイト D  
NEEDLE HOLE PLATE D  
(φ2.5 十文字溝付き)  
(φ2.5 cross-shaped groove)  
156152001

CODE	REF.NO.	PAGE
S00327001	K - 16	24
S00400000	K - 16-11	24
S01300009	N - 3	32
S01688001	E - 1	12
S02761009	Z - 17	40
S02773001	Z - 17-2	40
S02778002	Z - 17-6	40
S02780001	Z - 17-7	40
S02786002	Z - 17-11	40
S02878000	D - 21	12
S06706001	Z - 16	40
S07813001	H - 51	20
S07814001	H - 52	20
S09132001	F - 12	14
	H - 20	20
	H - 29	20
	H - 32	20
S13165001	J - 10	22
S13166001	J - 10-1	22
S18426001	T - 1	38
S21120001	D - 26	12
013710712	H - 37	20
	H - 40	20
	Q - 13	36
013719412	A - 32-8	2
013760612	A - 52	2
	G - 5	18
	M - 32	30
013761410	B - 32	6
013761412	C - 14	10
	C - 21	10
014680422	M - 28	30
	M - 34	30
	N - 1-18	32
014680622	K - 3	24
	Q - 3	36
	Q - 9	36
014760622	B - 34	6
	B - 74	8
	F - 18	14
	F - 23	14
	F - 3	14
	F - 30-3	14
	F - 32	14
	F - 35-7	14
	F - 6-2-3	14
	G - 10	18
	G - 16	18
	G - 28	18
	G - 4	18
	H - 10	20
	H - 45	20
	J - 19-3	22
	J - 21	22
	J - 30	22
	K - 11	24
	K - 17	24
	K - 6	24
	K - 8	24
	P - 26	34
	P - 30	34
	P - 42	34
	R - 10	36
	Z - 14	40
014770622	C - 17	10
	C - 19	10
	D - 8	12

CODE	REF.NO.	PAGE
014770622	K - 15	24
014821022	B - 6	6
	J - 29	22
017062503	Z - 23	40
017711412	B - 59	8
017761412	C - 9	10
	F - 40	16
017762012	S - 1-3	38
017762202	B - 66	8
018060822	J - 10-3	22
018061622	B - 77	8
	H - 42	20
018062022	B - 55-3	8
	H - 25	20
	H - 8	20
018062222	H - 18	20
018063022	F - 12-1	14
	H - 20-1	20
	H - 29-1	20
	H - 32-1	20
018081222	A - 32-3	2
018082022	F - 26-2-1	14
	F - 4-1	14
018082522	B - 11	6
018500822	F - 35-15	16
018501422	K - 25	24
018681022	P - 3	34
021060102	Z - 24	40
021100202	A - 32-15	2
021400106	S - 1-13-2	38
	Z - 12-2	40
021500106	Z - 17-4-2	40
	Z - 17-7-3	40
021670202	L - 12-7	26
021680202	B - 39-7	6
021800102	B - 22	6
025060132	B - 78	8
	P - 21	34
025060232	B - 80	8
	C - 10	10
	F - 39	16
	S - 1-4	38
025080132	A - 65	4
025080232	A - 32-4	2
	S - 1-7	38
025100132	A - 32-16	2
025350132	Q - 17	36
025350332	L - 12-4	26
	R - 4	36
025680132	B - 39-6	6
025770232	A - 11	2
	Q - 7	36
	R - 9	36
025800332	B - 20	6
	Z - 22	40
028040242	L - 51	28
028050242	B - 45	6
	B - 60	8
028050246	Z - 17-7-2	40
028060242	B - 79	8
	B - 82	8
	H - 27	20
	Z - 26	40
028080242	A - 32-5	2
	B - 12	6
	S - 1-8	38
028100242	A - 32-17	2

CODE	REF.NO.	PAGE
031452206	Z - 17-2-2	40
047251640	L - 37	26
047501242	A - 75	4
048030342	B - 39-4	6
	Q - 11	36
048040342	B - 27	6
	D - 55-2	8
	D - 1-5	12
	H - 43-4	20
	M - 30	30
	P - 18-3	34
	P - 28	34
	Q - 8	36
	R - 6	36
048050342	F - 35-6	14
	N - 1-17	32
	P - 37	34
	P - 5	34
	R - 8	36
048060342	G - 12	18
	G - 19	18
	Q - 4	36
048080342	K - 23	24
048100142	A - 32-13	2
048110142	B - 31	6
	B - 73	8
	G - 27	18
	P - 40	34
048120142	P - 24	34
048150142	C - 3	10
048160142	J - 26	22
048170142	J - 2	22
048180142	B - 4	6
	F - 15	14
	F - 22	14
048240242	D - 9-6	12
048320242	A - 32-2-1	2
048350142	D - 9-4	12
050501406	Z - 17-7-5	40
050503006	Z - 17-7-4	40
062060806	Z - 17-2-1	40
062401416	S - 1-13-3	38
	Z - 12-3	40
062501406	Z - 17-4-1	40
062660412	K - 16-4	24
062660712	D - 24	12
	K - 16-8	24
062670412	H - 49	20
	M - 45	30
062670512	A - 57	2
	L - 21	26
	L - 26	26
	L - 33	26
	L - 39	26
	L - 48	26
	L - 50	28
	Q - 15	36
062670612	L - 13	26
	M - 4	30
	M - 40	30
062670712	N - 1-19	32
	N - 1-9	32
062670812	A - 15	2
	L - 12-3	26
062671012	Q - 18	36
	R - 3	36
062671412	L - 12-8	26

CODE	REF.NO.	PAGE
062680612	A - 59	2
	L - 5	26
062680712	N - 1-11	32
062680812	A - 22	2
	A - 64	4
	C - 20-7	10
	L - 3	26
	L - 54	28
	N - 7	32
062710612	A - 72	4
062710712	A - 6	2
	M - 2	30
062711412	A - 5	2
	A - 8	2
062761412	A - 3	2
	N - 2	32
	P - 20	34
062781412	C - 35	10
071047650	F - 38	16
071095250	D - 25	12
072600360	J - 3-2	22
072600760	D - 9-2	12
072630260	C - 5	10
081003670	K - 13	24
	K - 19	24
	P - 52	34
081008070	T - 1-15	38
082104891	Z - 15-1	40
082105090	Z - 15-2	40
082105190	Z - 15-2	40
082105290	Z - 15-2	40
100032004	P - 43	34
100136001	M - 15	30
	M - 27	30
100250001	C - 16	10
100315002	A - 10	2
100360003	P - 16	34
	T - 1-9	38
100398001	M - 9	30
100402004	M - 10	30
100887001	Z - 4-2	40
101572101	Z - 3-3	40
101706001	C - 18	10
102538007	A - 56-3	2
102630001	G - 8	18
102716004	N - 1-22	32
	N - 1-5	32
102843004	C - 8	10
103950003	M - 18	30
104450109	A - 31	2
	A - 66	4
104525001	M - 14	30
	N - 3-3	32
104567001	L - 10	26
	L - 22	26
	L - 40	26
104689002	B - 23	6
	K - 2	24
105248003	L - 65	28
105451002	F - 10	14
	F - 25	14
105812003	S - 1-9	38
106030001	Z - 19	40
106129001	A - 56-4	2
106147002	B - 37	6
107038003	F - 35-12	16
107149001	J - 27	22

CODE	REF.NO.	PAGE
107149001	L - 59	28
107153002	G - 11	18
	G - 18	18
107231002	J - 9	22
107415009	C - 27	10
	Z - 9	40
107415016	C - 27	10
	Z - 9	40
107606001	M - 14	30
107744001	B - 39-2	6
107780001	Z - 4-3	40
108265009	N - 3-4	32
108520009	A - 30	2
109239002	A - 18	2
109893002	H - 26	20
110027001	H - 44	20
110251001	B - 38	6
	B - 67	8
110495003	K - 14	24
110505001	B - 72	8
111140002	P - 13	34
	T - 1-8	38
111865009	B - 75	8
	P - 41	34
112468001	P - 36	34
112669001	L - 31	26
	L - 42	26
	L - 56	28
112751003	M - 6	30
113006001	L - 34	26
113316001	M - 5	30
113431002	B - 39-5	6
	B - 61	8
114294001	M - 17	30
114483002	Z - 10	40
114486002	A - 71	4
114985001	A - 58	2
115003001	D - 1-3	12
115012002	B - 13	6
115018001	B - 19	6
115077003	M - 38	30
115138001	N - 1-13	32
115157001	Z - 5-5	40
115493002	A - 17	2
116016001	S - 1-13-4	38
	Z - 12-4	40
116185209	S - 1-13	38
	Z - 12	40
116629001	Q - 5	36
116920001	C - 36	10
117150001	L - 25	26
	L - 38	26
117363001	B - 44	6
117437109	S - 1-13-1	38
	Z - 12-1	40
117934009	A - 29	2
117936009	A - 27	2
118064001	Z - 5-3	40
118837001	Z - 3-2	40
120448001	N - 1-21-2	32
	Z - 30	40
122991001	Z - 1	40
126863001	Z - 17-10	40
132051001	C - 20-4	10
140208001	M - 29	30
	P - 27	34

CODE	REF.NO.	PAGE
140392009	A - 28	2
140407002	F - 35-14	16
140423000	L - 2-5	26
	L - 28	26
140726000	C - 11	10
141331001	F - 36-3	16
141334001	H - 47	20
	P - 48	34
141472002	J - 23	22
141528001	M - 37	30
141550001	N - 1-14	32
141583001	G - 21	18
141692001	L - 12-6	26
141786001	K - 1	24
141808001	K - 34	24
141860001	A - 32-2-2	2
142002001	Z - 5-1	40
142211001	C - 33	10
142443001	Z - 3-1	40
142566001	N - 1-16	32
142628001	B - 30	6
	B - 71	8
	G - 26	18
	P - 39	34
142721001	Z - 5-2	40
143591001	F - 35-5	14
144226001	Z - 25	40
144458001	C - 24	10
144588001	M - 11	30
144694001	L - 6	26
144712002	C - 2-1	10
145318001	F - 34	14
145446001	M - 12	30
	M - 22	30
	N - 3-2	32
145478001	F - 35-17	16
145480001	A - 12	2
145519001	M - 11	30
145646019	C - 27	10
	Z - 9	40
146375000	L - 23	26
147111001	D - 7	12
147151000	H - 3	20
147745000	L - 15	26
	L - 2-6	26
	L - 43	26
148921000	L - 14	26
149247001	S - 1-12	38
	Z - 18	40
150106003	Z - 17-4	40
150172003	Z - 17-3	40
150174000	Z - 17-5	40
150179002	Z - 17-7-1	40
150180001	Z - 17-8	40
150182000	Z - 17-9	40
150189009	Z - 17-1	40
150335001	Z - 5-4	40
150553001	B - 53	8
	B - 64	8
	P - 33	34
	S - 1-5	38
150554002	B - 14	6
150556001	B - 46-3	6
	B - 48	6
	B - 51	6
	G - 20-3	18
	G - 22	18

CODE	REF.NO.	PAGE
151163001	B - 9	6
	H - 24	20
151602002	F - 1-3	14
151604002	A - 54	2
151886001	B - 1	6
151887001	B - 3	6
151888101	B - 10	6
151889001	B - 15	6
151890000	B - 16	6
151891001	B - 17	6
151892001	B - 18	6
151893001	B - 21	6
151894101	B - 24	6
151895000	B - 25	6
151898001	B - 26	6
151899001	B - 28	6
151900001	B - 29	6
151901001	B - 33	6
151902001	B - 35	6
151903001	B - 36	6
151904101	B - 39	6
151905101	B - 39-1	6
151906101	B - 39-3	6
151907001	B - 40	6
	B - 54	8
	P - 32	34
151908001	B - 41	6
151910001	B - 43	6
151912001	B - 47	6
151913001	B - 49	6
151914001	B - 50	6
151915101	B - 52	6
151919101	B - 57	8
151920001	B - 58	8
151922001	B - 65	8
151923001	B - 68	8
151924001	B - 69	8
151925001	B - 70	8
151927001	B - 2	6
151928001	J - 1	22
151929000	B - 7	6
151930201	J - 3-1	22
151932001	J - 8	22
151933001	J - 10-1	22
151935000	J - 10-1-1	22
151936001	J - 11	22
151937001	J - 12	22
151938001	J - 13	22
151939101	B - 55	8
151940001	J - 10-2	22
151941101	J - 10-4	22
151944001	J - 19	22
151946000	D - 17	12
151947101	J - 19-1	22
151948001	J - 19-2	22
151949001	J - 20	22
151951001	J - 22	22
151952001	J - 24	22
151953001	J - 25	22
151954001	J - 28	22
151995001	C - 1	10
151997000	C - 4	10
151998000	C - 6	10
151999001	C - 7	10
152000001	C - 13	10
152191101	K - 9	24
152231000	C - 15	10

CODE	REF.NO.	PAGE
152232001	C - 20	10
152236001	C - 20-2	10
152237001	C - 20-3	10
152238001	C - 20-5	10
152239001	C - 20-6	10
152240001	C - 22	10
152242001	C - 25	10
152243001	C - 26	10
152244000	C - 34	10
152245001	K - 4	24
152246001	K - 5	24
152247001	K - 7	24
152250001	K - 10	24
152677001	K - 16-1	24
152678001	K - 12	24
	K - 18	24
152679001	K - 16-2	24
152680001	K - 16-3	24
152681201	K - 24	24
152682001	K - 26	24
152683001	K - 16-5	24
152684001	K - 16-6	24
152685101	K - 31	24
152686001	K - 26	24
152687001	K - 31	24
152693001	D - 1-1	12
152694001	D - 1-2	12
152695201	D - 9-1	12
152698001	D - 9-3	12
152699001	D - 9-5	12
152700000	D - 9-7	12
152701001	D - 18	12
152702001	D - 19	12
152703100	D - 20	12
152705101	D - 22	12
152706001	D - 23	12
152707001	H - 1	20
152708000	H - 4	20
152709000	H - 6	20
152710001	H - 7	20
152713001	H - 5	20
152718001	H - 2	20
152719000	H - 15	20
152720000	H - 16	20
152721000	H - 15	20
152722000	H - 16	20
152723001	H - 34	20
152724001	H - 19	20
152726001	H - 22	20
152727001	H - 22	20
152728001	B - 8	6
	H - 23	20
152729001	H - 28	20
152731001	H - 35	20
152732001	H - 36	20
152733001	H - 39	20
152734001	H - 41	20
152735101	H - 43	20
152739001	H - 43-2	20
152741101	F - 1	14
152742001	F - 1-1	14
152744001	G - 2-2	18
152745001	F - 2	14
	F - 31	14
152749001	F - 27	14
	F - 7	14
152750001	F - 28	14



CODE	REF.NO.	PAGE
152750001	F - 8	14
152751101	F - 6-2	14
152752001	F - 6-2-1	14
152755001	F - 11	14
152756001	B - 5	6
	F - 14	14
	F - 19	14
	F - 21	14
152758001	F - 16	14
152759001	F - 17	14
152760001	F - 20	14
152762001	F - 30	14
152765001	Z - 6	40
152766001	F - 33	14
152767009	F - 35	14
152768009	F - 35-1	14
152769001	F - 36	16
152771000	F - 36-1	16
152772001	F - 37	16
152773000	F - 36-2	16
152774001	F - 35-2	14
152775001	F - 35-3	14
152776001	F - 35-4	14
152777001	F - 35-8	14
152778001	F - 35-9	14
152779001	F - 35-8	14
152780001	F - 35-9	14
152783001	F - 35-10	14
152784001	F - 35-11	14
152788000	F - 35-19	16
152791201	F - 44	16
152794001	G - 1	18
152797001	G - 2	18
152798001	G - 2-1	18
152799001	G - 3	18
152800201	G - 6	18
152801001	G - 7	18
152802001	G - 9	18
152803001	G - 13	18
152805101	G - 14-1	18
152806001	G - 14-2	18
152808101	B - 46	6
	G - 20	18
152811001	G - 23	18
152815001	Q - 1	36
152816001	Q - 2	36
152822001	Q - 6	36
152823001	Q - 10	36
152827009	Q - 12	36
152830109	A - 2	2
152831009	A - 4	2
152832109	A - 4-1	2
152833001	A - 4-2	2
152834009	A - 7	2
152835009	A - 9	2
152836009	A - 13	2
152838001	A - 60	2
152839001	A - 61	4
152841009	A - 14	2
152842009	A - 16	2
152846009	A - 19	2
152847009	A - 77	4
152848001	A - 63	4
152852101	A - 32-2	2
152857001	A - 32-6	2
152858001	A - 32-7	2
152859001	A - 32-9	2

CODE	REF.NO.	PAGE
152860009	A - 32-10	2
152861101	A - 32-11	2
152862001	A - 32-12	2
152863001	Z - 20	40
152864000	Z - 21	40
152865101	A - 32-14	2
152866001	A - 51	2
152867000	A - 53	2
152868009	A - 55	2
152869001	M - 1	30
152870001	M - 3	30
152872001	M - 8	30
152873001	M - 16	30
152874001	M - 19	30
152875001	M - 20	30
152876001	M - 21	30
152877001	M - 23	30
152878001	M - 24	30
152879101	M - 25	30
152880001	M - 26	30
152881001	M - 31	30
152883000	M - 43	30
152884001	M - 44	30
152886001	M - 33	30
152887001	M - 35	30
152888101	M - 36	30
152889001	M - 39	30
152890001	M - 41	30
152891001	M - 42	30
152892001	P - 1	34
152893101	P - 4	34
152896001	P - 2	34
152897201	P - 9	34
	T - 1-4	38
152901001	P - 10	34
	T - 1-5	38
152904001	P - 11	34
	T - 1-6	38
152905001	P - 12	34
	T - 1-7	38
152906101	P - 50	34
	T - 1-13	38
152912001	P - 18-1	34
152913001	P - 18-2	34
152914001	B - 55-1	8
	H - 38	20
	P - 18-4	34
152915001	P - 19	34
152916001	P - 22	34
152917001	P - 23	34
152919001	P - 18-6	34
152920001	P - 29	34
152921001	P - 31	34
152922001	P - 34	34
152923001	P - 35	34
152925101	R - 1	36
152926001	R - 2	36
152929001	R - 7	36
152933001	N - 1-3	32
152934001	N - 1-4	32
152935001	N - 1-6	32
152936001	N - 1-7	32
152937001	N - 1-8	32
152938001	N - 1-10	32
152939001	N - 1-12	32
152940001	N - 1-15	32
152941001	N - 1-20	32

CODE	REF.NO.	PAGE
152945001	N - 3-1	32
152948001	L - 1	26
	L - 11	26
152949001	L - 2	26
152950001	L - 2-1	26
152951001	L - 2-2	26
152952001	L - 2-3	26
152953001	L - 45	26
152955001	L - 4-2	26
152956001	L - 4-3	26
	L - 7	26
152958001	L - 4	26
152959001	L - 4-1	26
152960001	L - 9	26
152961001	L - 12	26
152962001	L - 8	26
152963001	L - 12-5	26
152964001	L - 17	26
	L - 19	26
152965001	L - 18	26
152966001	L - 12-1	26
152967001	L - 12-2	26
152968001	L - 60	28
152969001	L - 20	26
	L - 32	26
152971001	L - 29	26
152973001	L - 36	26
	L - 67	28
152974001	L - 41	26
152976001	L - 49	28
152977001	L - 52	28
152978001	L - 53	28
152980001	B - 52-1	8
	F - 6-2-4	14
	L - 70	28
152981001	P - 7	34
	T - 1-2	38
152982109	N - 1	32
152983009	N - 1-1	32
152984001	N - 1-2	32
152985001	L - 46	26
152986001	A - 21	2
152988001	R - 5	36
152989001	A - 20	2
152992001	L - 24	26
152995001	P - 6	34
	T - 1-1	38
153033009	F - 35	14
153035000	F - 43	16
153040001	C - 2	10
153041001	F - 1-2	14
153042001	F - 26-1	14
	F - 6-1	14
153043001	F - 30-2	14
	F - 6-2-2	14
153044001	D - 1	12
153045001	F - 24	14
	F - 9	14
153047001	F - 6	14
153048001	F - 26	14
153049001	M - 7	30
153050000	K - 16-9	24
153053001	H - 22	20
153054001	H - 22	20
153055201	F - 44	16
153056201	A - 62	4
153056202	A - 62	4

CODE	REF.NO.	PAGE
153056203	A - 62	4
153056204	A - 62	4
153056205	A - 62	4
153056206	A - 62	4
153056207	A - 62	4
153056208	A - 62	4
153056209	A - 62	4
153057002	F - 42	16
153058001	D - 1-4	12
153098000	A - 56-2	2
153100000	A - 56	2
153102001	A - 56-1	2
153104001	H - 17	20
153108001	Z - 13	40
153109001	Z - 13	40
153138001	M - 46	30
153141001	H - 48	20
153195001	H - 43-3	20
153207201	F - 44	16
153208002	P - 44	34
153219001	P - 46	34
	T - 1-12	38
153220001	P - 45	34
	T - 1-11	38
153222001	P - 8	34
	T - 1-3	38
153312000	H - 15	20
153313000	H - 16	20
153314001	H - 22	20
153315001	H - 22	20
153321001	H - 22	20
153330001	C - 20-1	10
153331001	F - 30-1	14
153332001	H - 43-1	20
153343001	H - 22	20
153344001	H - 22	20
153482001	P - 38	34
153528001	L - 64	28
153529101	L - 61	28
153530001	L - 62	28
153531001	L - 63-1	28
153562001	L - 63-2	28
153567000	F - 35-20	16
153568001	F - 35-18	16
153570001	F - 35-16	16
153571001	F - 35-13	16
153574201	Z - 28	40
153596001	P - 54	34
	T - 1-17	38
153597001	P - 53	34
	T - 1-16	38
153598001	P - 51	34
	T - 1-14	38
153608101	F - 35-8	14
153610101	F - 44	16
153757001	F - 26-2	14
153762101	F - 4	14
153763001	L - 47	26
153918001	L - 2-4	26
153919001	L - 2-7	26
153921001	F - 1-5	14
153922001	L - 44	26
	L - 58	28
153924001	F - 1-4	14
153925001	L - 68	28
153926001	L - 69	28
153927001	L - 55	28

CODE	REF.NO.	PAGE
154155101	B - 63	8
154332001	B - 46-1	6
	G - 20-1	18
154333001	B - 46-2	6
	G - 20-2	18
154339001	K - 35-1	24
154341001	K - 35-2	24
154356001	F - 35-18	16
154448001	S - 1-2	38
154449001	S - 1-6	38
154450001	S - 1-10	38
154451001	S - 1-11	38
154452001	S - 1-1	38
154465001	A - 70	4
154526009	F - 35	14
154527001	F - 35-9	14
154528001	N - 1-21-1	32
154540001	Z - 13	40
154541001	Z - 13	40
154542001	Z - 13	40
154543001	Z - 13	40
154681001	S - 1-14	38
154702001	Z - 11	40
154709002	S - 1	38
154738109	A - 32-1	2
154760001	Z - 31	40
154785000	A - 74	4
154788001	P - 25	34
154789001	P - 18-5	34
155336001	H - 46	20
155337001	H - 43-5	20
155489000	K - 16-10	24
155499001	B - 62	8
155500001	B - 76	8
155501001	B - 42	6
155523001	J - 10	22
156149001	P - 17	34
156150001	P - 17	34
	T - 1-10	38
156151001	P - 17	34
156206001	Q - 14	36
156495001	Q - 16	36
156936101	J - 3	22
158686001	G - 15	18
158687001	G - 24	18
159610101	K - 35	24
159612001	K - 35-3	24
159613001	K - 36	24
	Z - 7	40
159805001	M - 13	30
159808109	A - 32	2
159977000	H - 9	20
159978001	H - 11	20
159979001	H - 12	20
159984001	H - 13	20
183686001	D - 9	12
402887001	K - 16-7	24

brother

**ブラザー工業株式会社**

〒467 名古屋市瑞穂区河岸一丁目1番1号  
TEL (052) 824-2392代

**BROTHER INDUSTRIES, LTD. NAGOYA, JAPAN**

118-430  
195430-501 ©  
1993, 02

**A**

Printed in Japan/Gedruckt in Japan/Imprimé au Japon/Impreso en Japón